



DR ZĄBER

- The designing, the construction of machines and technological devices
- The modernization of machines
- The process automation productive
- The modernization of machine tools in this the construction of machine tools CNC on the basis of machine tools of old types
- The designing of injection's forms
- The designing, the construction of towers and telephone and teletype service masts
- Wind power stations
- The designing of small hydroelectric power stations
- Deliveries of the equipment of small hydroelectric power stations
- Works searchingly – of development in the sphere of technology
- The technical support

DR ZĄBER LLC

33-300 Nowy Sącz, ul. Magazynowa 1 tel. : (18) 415 60 21
Fax: (18) 415 60 22 e-mail: zefir@zaber.com.pl www.zaber.com.pl
NR KRS 0000144200 NIP: 734-29-42-720 REGON: 492839371
Company Capital: 1 300 000 zł



ZEFIR D14-P10-T23
WIND TURBINE

MANUFACTURER'S GUIDELINES FOR THE CONSTRUCTION PROJECT

Project number: 0195-2010-Series ZEFIR D14-P10-T23

Developed by:

mgr inż. Marek Brzeziński
mgr inż. Jakub Potoczek
mgr inż. Grzegorz Pudło
mgr Joanna Wnęk
mgr inż. Kacper Ząber
mgr inż. Krzysztof Ząber
dr inż. Zdzisław Ząber

DR ZĄBER Sp. z o.o.
Vice PREZES ZARZĄDU
mgr inż. Marek Brzeziński

DR ZĄBER Sp. z o.o.
PREZES ZARZĄDU
dr inż. Zdzisław Ząber

1. Table of contents

1. Table of contents.....	2
2. Introduction.....	3
3. Basic specifications.....	4
4. Guidelines for the construction project.....	8
4.1 Anchor bolts.....	8
4.2 Pipes and cables in a foundation block.....	13
5. Computational load cases of the wind turbine foundation.....	15
5.1. Wind turbine operates at a nominal power.....	16
5.2. Turbine's failure at the turbine set's nominal power.....	17
5.3. Extreme wind blast in the rotor's axis at a stoppage.....	18
5.4. Extreme wind blast from the side at a stoppage.....	19
6. 6 Example of foundation.....	20
7. Installation of the turbine set.....	22
8. Energetic installation.....	27
8.1. On-grid installation with the inverter located on the tower of the turbine set.....	27
8.2 On-grid installation with inverter in the building.....	29
8.3 Off-grid installation.....	31
8.4. Schematic diagrams of the system main components.....	33
9. Grounding and lightning protection.....	35

2. Introduction

Wind turbine ZEFIR D14-P10-T23 is a modern machine designed for the processing of wind energy into electricity. It was developed by an experienced team of designers and used solutions are the result of the collected nearly twenty years of experience and thorough knowledge in the field of wind energy. It uses advanced technical solutions, including a low speed generator with permanent magnets, pitch control, friction disc brake on the main shaft, the active yaw mechanism, remote monitoring and MPPT algorithms in the control system. Therefore it is a power plant having most of the features of modern, large wind turbines.

This turbine is a universal machine, possible to use both to operate in an off-grid and on-grid system. The type of operation depends on the selected electro-energetic equipment.

Turbine ZEFIR D14-P10-T23 is a machine consisting of six closely related components. These are:

1. The carrier body in the form of a tubular tower.
2. Yaw mechanism mounted on the top of the tower. Yaw mechanism is a component used for the orientation of the turbine rotor to the wind.
3. Nacelle, a support structure used to support the turbo-generator and to shield sensitive elements associated with it.
4. Turbogenerator, a wind turbine (wind engine) with a generator on a common shaft. This component converts wind energy into electricity. It includes also built-in control systems of the wind turbine and a safety friction brake.
5. Cabinet of electrical and control equipment. It includes both the special microprocessor control system and electrical equipment of wind turbine executive systems.
6. Energetic cabinet: loads controller or inverter, depending on the on-grid or off-grid turbine application. The cabinet can be located on the turbine tower or in the energy consumers building, depending on the local conditions.

The machine described above is supplied by the manufacturer together with a declaration of conformity and marked with the CE mark. This machine is intended to be mounted on individually designed foundation. The foundation must be designed by a construction designer qualified to such works.

Energetic installation of the turbine for connecting turbine set to the consumer's grid must also be designed by an electrical designer qualified for such works.

3. Basic specifications

Fig. 1 and 2 below show the dimensions of the ZEFIR ZEFIR D14-P10-T23 wind turbo-generator.

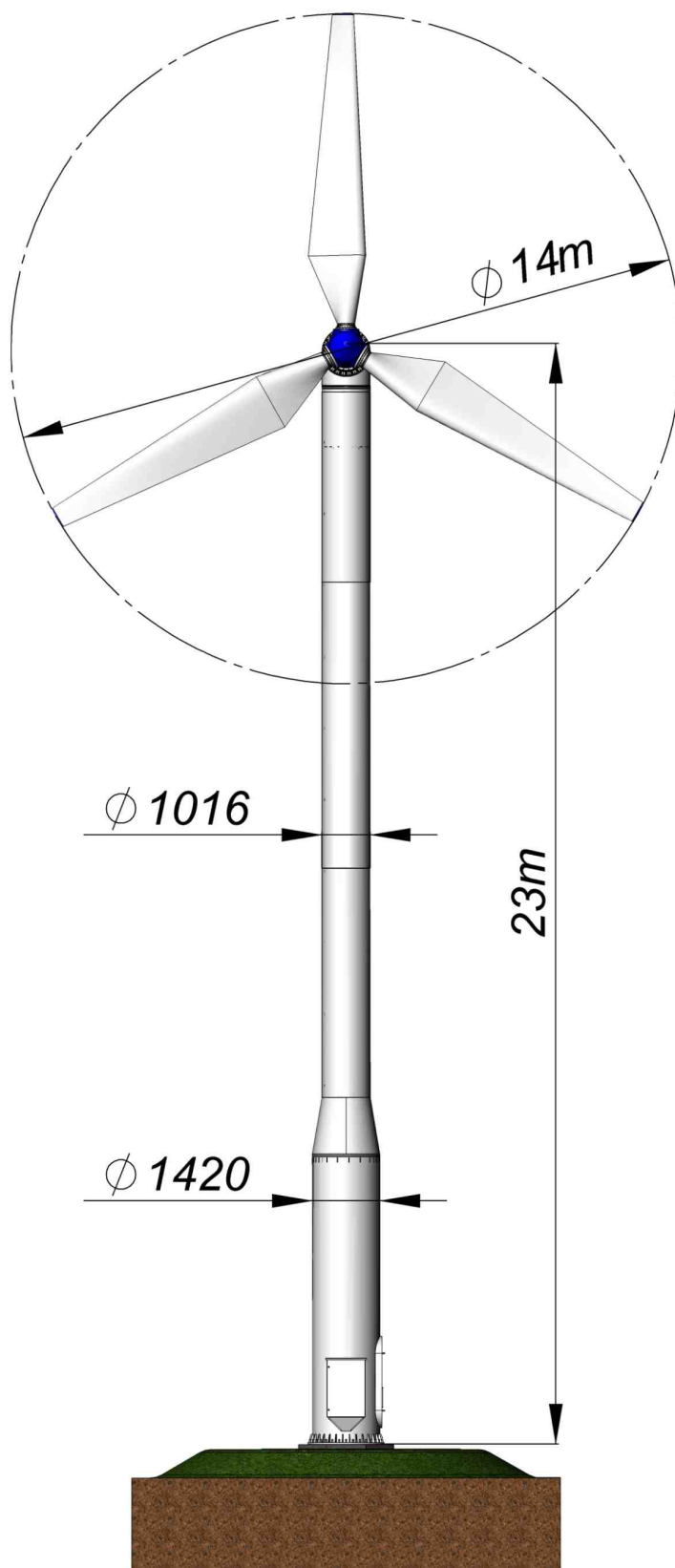

Fig.1. ZEFIR D14-P10-T23 wind turbo-generator. Front view.

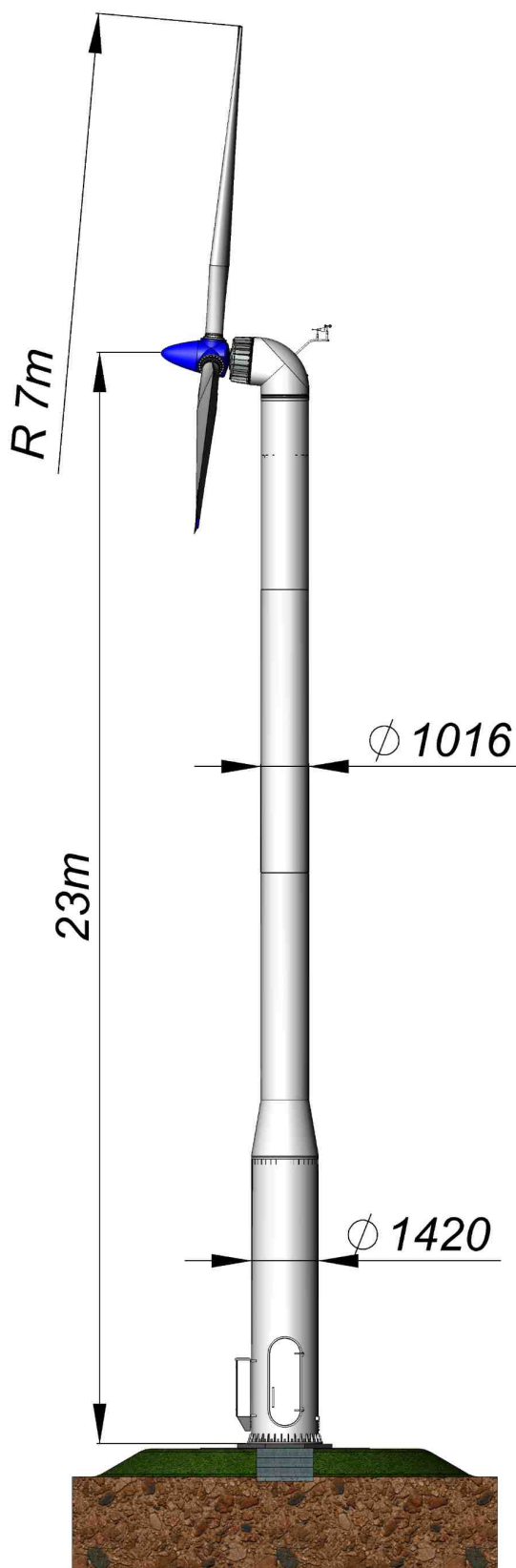

Fig.2. ZEFIR D14-P10-T23 wind turbo-generator. Side view.

The annex to this document contains the file „ZEFIR D14-P10-T23.dwg” for the designer architect.

Wind turbine ZEFIR D14-P10-T23 is one of the series of machines with the same name. For unambiguous identification, in the trade name were placed symbols having the following meaning:

D14- rotor diameter of the wind turbine in meters

P10- nominal power of the wind turbine in kilowatts

T23- rotor axis mounting height above the ground in meters

Table 1 summarizes the basic specifications of the ZEFIR D14-P10-T23 wind turbine, and Fig.3 shows the characteristics of its energy performance in the form of the power curve.

Table 1. Basic specifications of the ZEFIR D14-P10-T23 wind turbine

Class of the turbine set according to EN 61400-2:2014	II
Rotor diameter	D=14[m]
Nominal electric power of the wind turbine	P=10[kW]
Rotor axis mounting height above the ground	H=23[m]
Number of rotor blades	Z= 3
Location of the rotor during operation	In front of the tower
Rotation direction of the rotor	Clockwise
Rotor blades material	Fiberglass reinforced with resin
Wind turbine power control	Pitch control
Total height of the power plant (with the rotor)	Hc=29.8[m]
Wind speed at nominal power (10-minute average)	7.2[m/s]
Turbine starting wind speed (10-minute average)	3.0[m/s] increasing 15.0[m/s] descending
Turbine stopping wind speed (10-minute average)	2.0[m/s] descending 20.0[m/s] increasing
Turbine rotor nominal speed	n=60[obr/min]
Turbine rotor speed range	$\Delta n=18\div 75$ [obr/min]
Turbogenerator weight with nacelle and yaw mechanism (weight of the turbine head)	Gt=2717[KG]
Head's center of gravity: -relative to the tower's axis -over the tower's	flange e=0.92m h=0.75m

Table 1. Continued

Gearbox	Gearless system
Generator type	Synchronous permanent magnet generator
Generator nominal voltage	400V AC, 50Hz
Inverter input voltage range	100÷500V AC
Inverter nominal output voltage	400V AC, 50Hz
THD coefficient	<3%
Yaw mechanism	Active with cable twisting control
Noise emission	<85dBA
Outer diameter at the base of the tower	Dw=1420[mm]
Outer diameter at the top of the tower	Ds=1016[mm]
Tower height	HT=21.8[m]
Number of tower segments	2
Access to the nacelle	Internal ladder
Tower weight including electrical equipment	6.56[T]

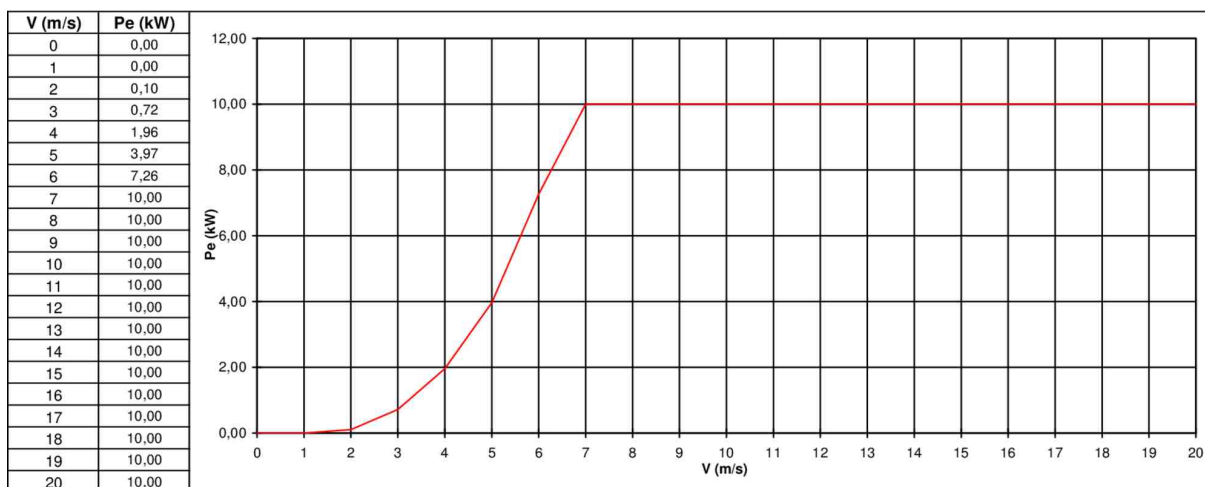

Fig. 3. ZEFIR D14-P10-T23 power curve. V(m/s) – wind speed in the rotor axis, P(kW) - Electrical power at the inverter output.

4. Guidelines for the construction project

4.1 Anchor bolts

The wind turbine set must be mounted on the foundation as shown in Fig.4.

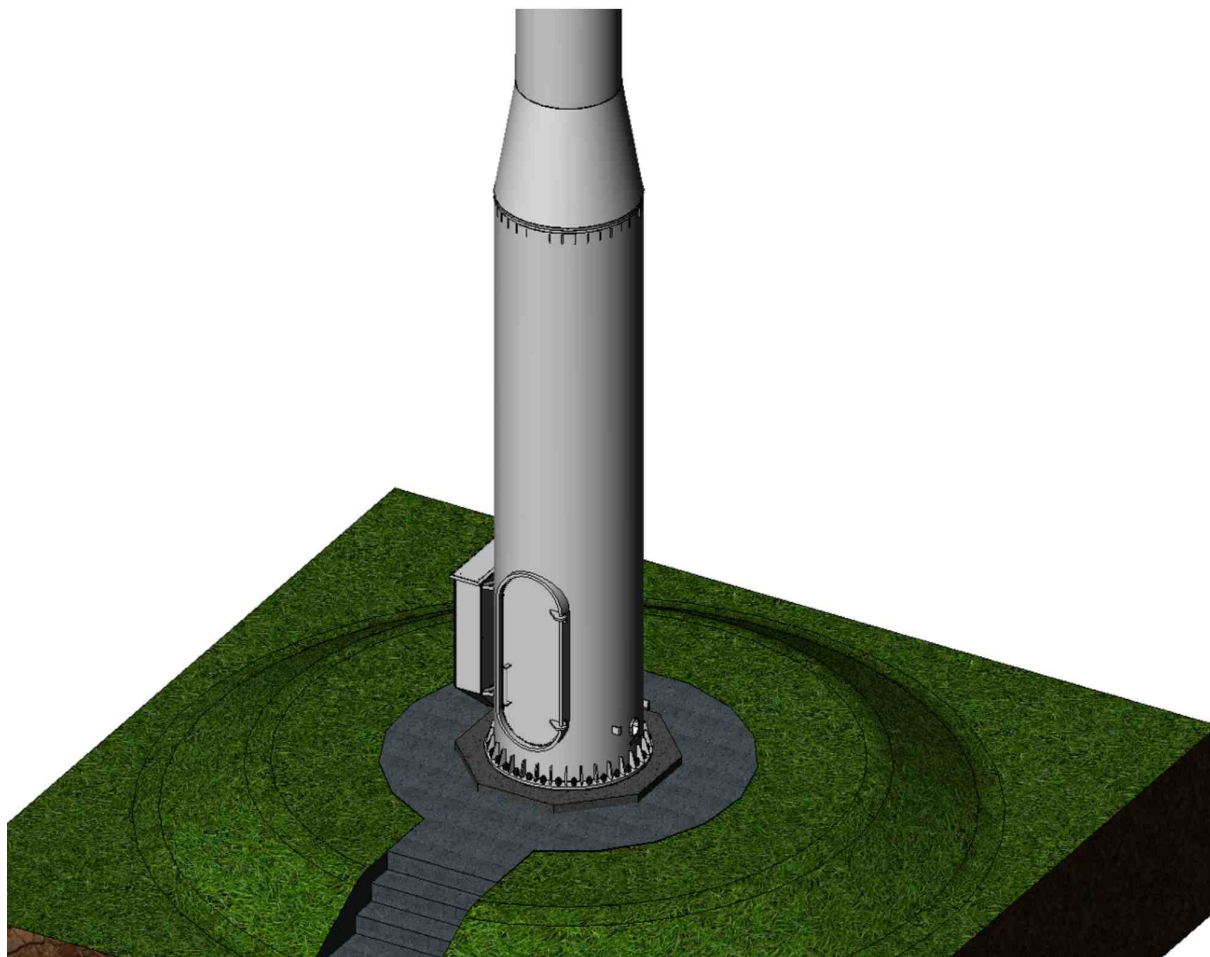

Fig.4. ZEFIR D14-P10-T23 turbine set placement on a foundation.

32 threaded M30 anchor bolts should be led out from the foundation, made with S355J2 (18G2A) steel, evenly spaced on a circle with a $\text{O}1500\text{mm}$ diameter, fig.5 and 6.

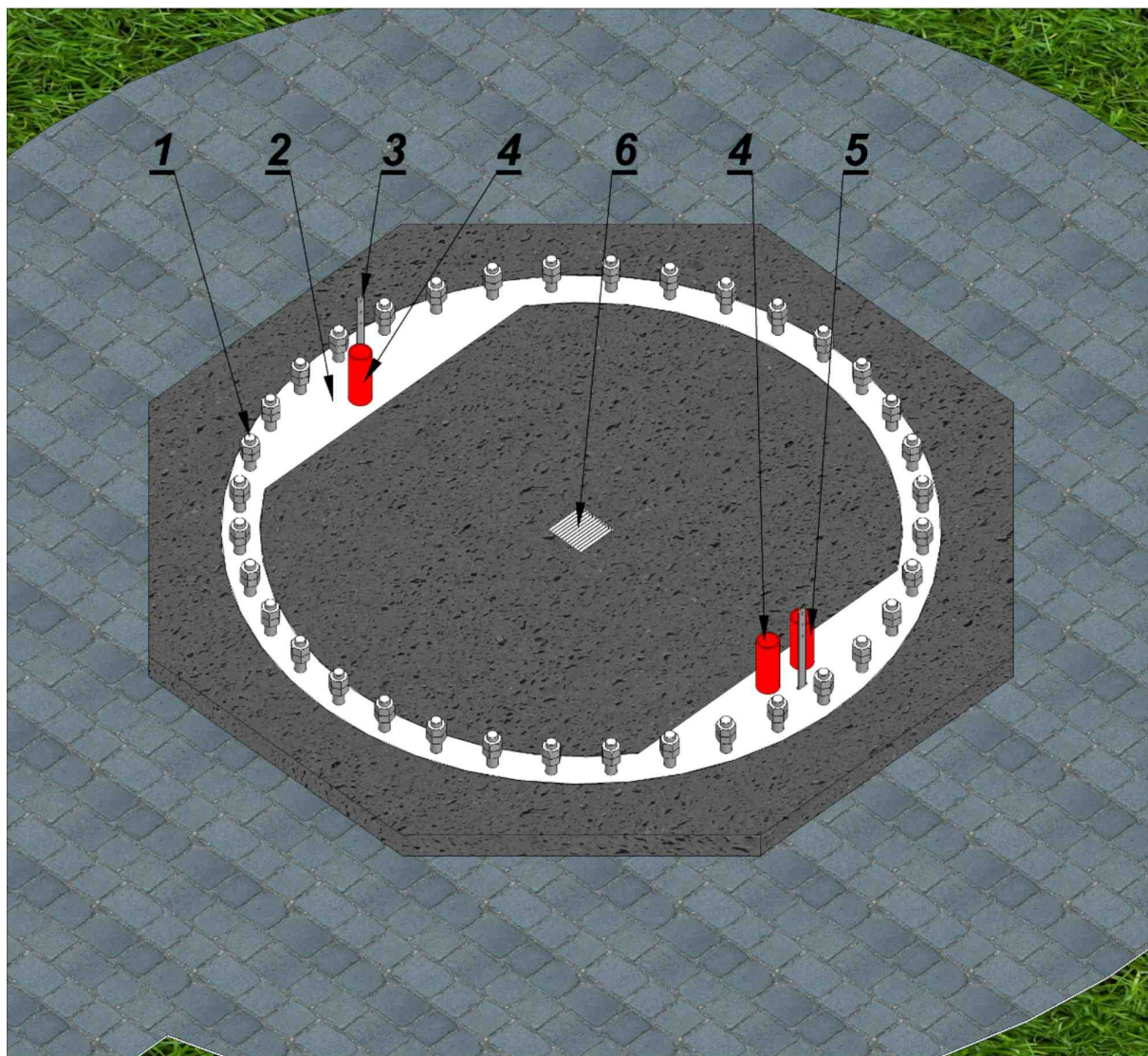

Fig.5. Mounting surfaces and the foundation anchors of the ZEFIR D14-P10-T23 turbine set.

1- threaded anchors, 2- the upper ring of the anchor basket, 3- grounding flat bar, 4,5- cable protective tubes, 6- dewatering well

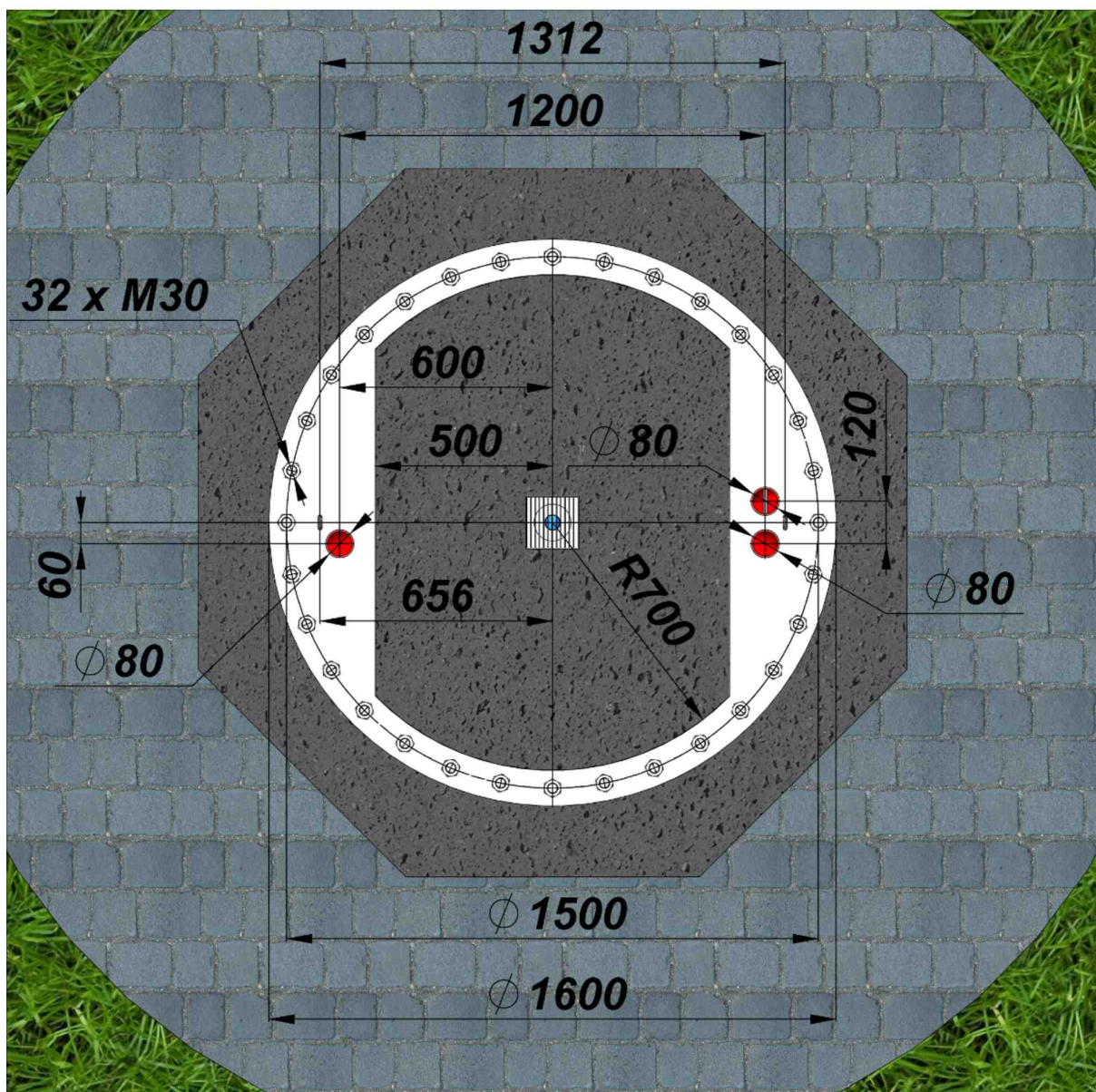

Fig.6. The proposed solution for the ZEFIR D14-P10-T23 turbine set anchor basket.

Anchor bolts must be routed through the $\text{O}1600/\text{O}1400$ steel flange, made of sheet metal with a minimum thickness of 20mm. Anchor bolts must protrude more than 100mm over the flange, Fig. 7.

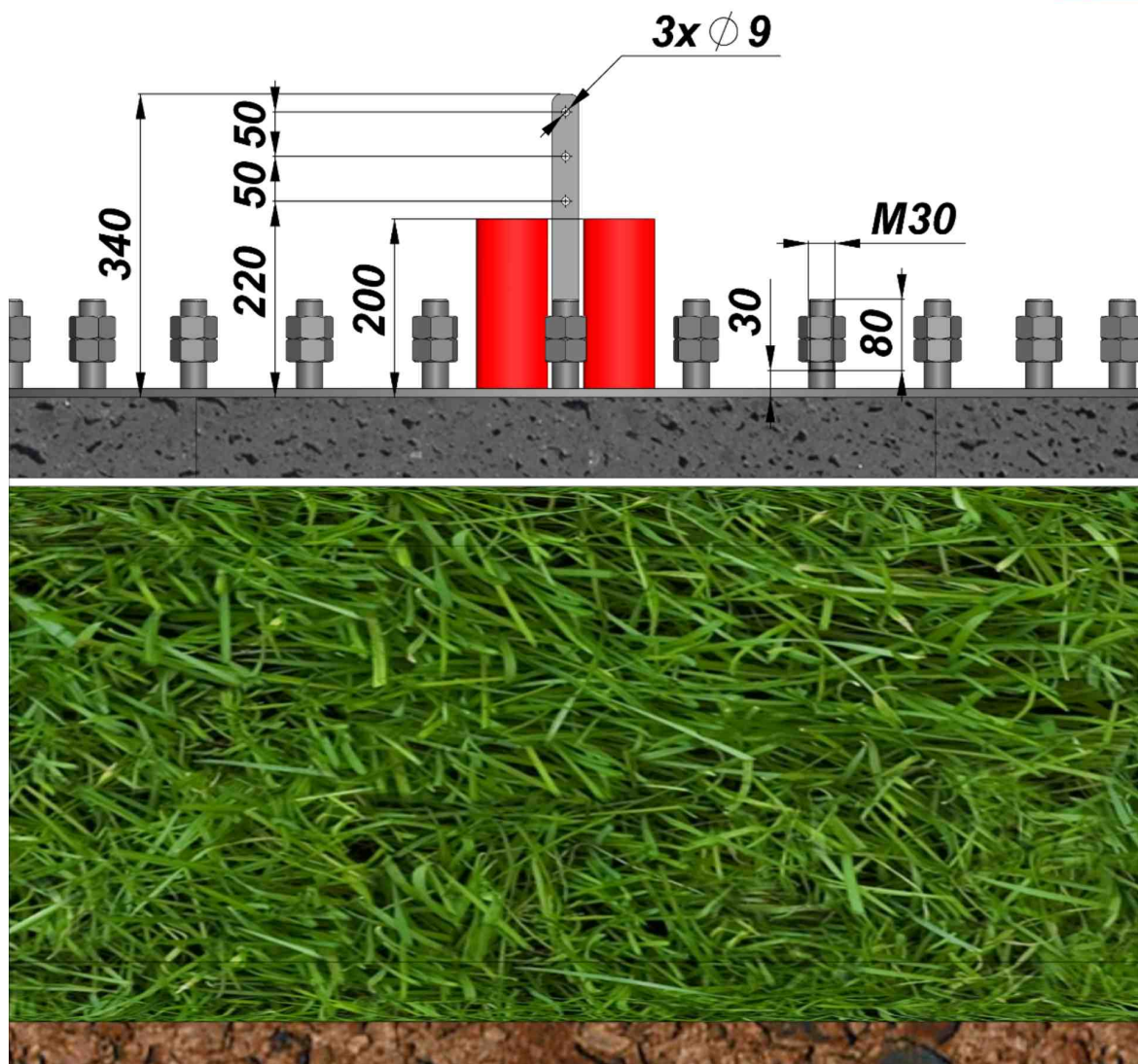

Fig.7. Grounding and protective pipes lead out from the ZEFIR D14-P10-T23 turbine set foundation.

The bottom flange of tower is made of steel sheet with a 30mm thickness. Hence the above-mentioned recommendation, that anchors thread should began not higher than 30mm above the upper flange of the anchor basket.

Figure 8 shows an example embodiment of the set of anchors called the anchor basket.

There are two files in DXF format attached to this document, according to which should be cut:

- the top flange (ZEFIR Top anchor flange.dxf),
- the bottom flange (ZEFIR Bottom anchor flange.dxf) of anchor basket.

The desired position of the flange against the upper ends of the threaded anchors can be fixed by imposing spacer PVC pipes between the flanges on the several anchors.

It is unacceptable to weld anchors to the rings. It is recommended to protect the anchor upper threads and the upper basket flange against the corrosion by galvanizing.

In the bottom ring it is recommended to embed 4 feet with adjustable height for the anchor basket leveling.



Fig.8. The ZEFIR D14-P10-T23 anchor basket.

4.2 Pipes and cables in a foundation block

In the foundation, place two protective tubes for the power output cable and the standby consumption cable, by order min. $\varnothing 60$ and min. $\varnothing 28$ in the case of operations in an off-grid system or an on-grid system with the inverter not in the tower, and one pipe min. $\varnothing 60$ when the inverter is installed on the tower in case of an on-grid system. In addition, flat grounding bar must be led out. Grounding bar should be welded to the bottom grid armament and the end of it led out outside the foundation block. In the tower, grounding bar and protective pipes should be led out over the level of the upper flange of the anchor basket, as shown in Fig.7. Their location relative to mast entrance is important. In addition, it is recommended to make a dehydration of tower's interior. This dehydration is intended to drain the water vapor condensate produced in certain weather conditions on the internal walls of tower.

A proposal for leading of protective pipes was shown in Fig.9. The cable protective pipes should be led out from the foundation towards energy consumers building.

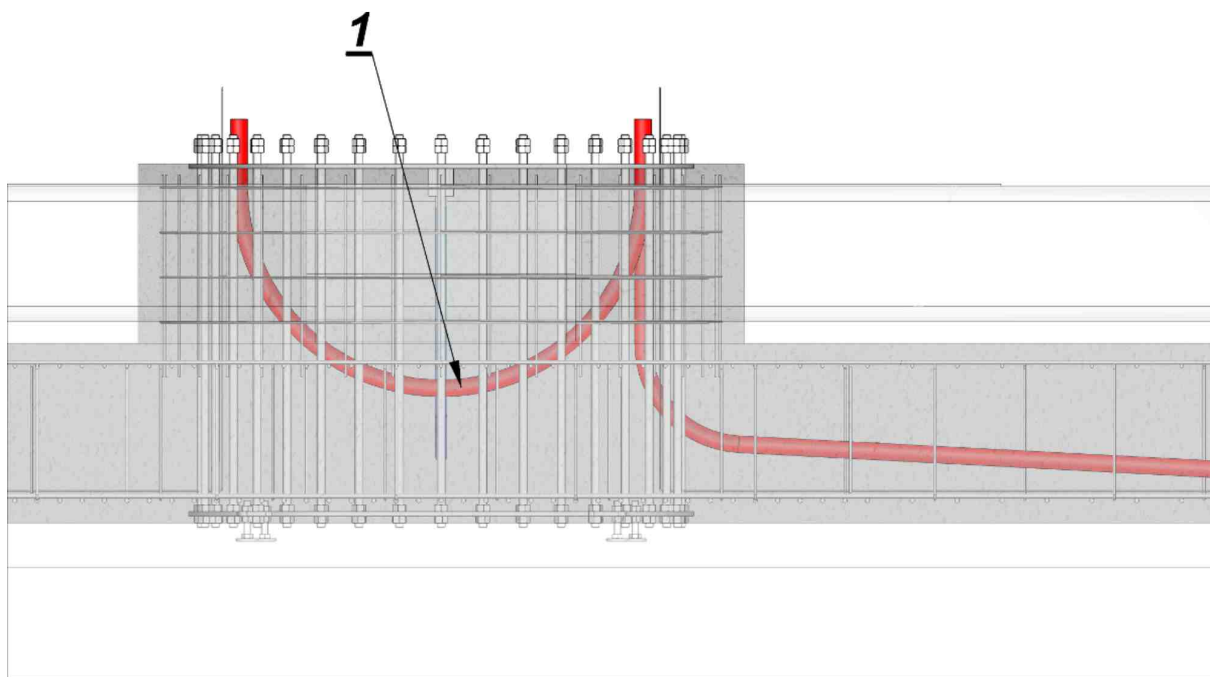

Fig. 9. Grounding bar and protective pipes led out from the ZEFIR D14-P10-T23 turbine set foundation.

1- Cable protective pipes

Protective pipes bending radius should be maximally possible with the limitations resulting from the size of the foundation. It is advisable before concreting the foundation, to lead into protective pipes a $\varnothing 5\text{mm}$ steel wires used for pulling cables. It should be ensured that during bending of protective pipes and during foundation concreting there will not be any loss of patency.

Power and signal cables should be lead out from protective pipes, in the way that they will protrude min. 1.5m above the level of the foundation anchor upper ring.

On Fig.10. was signaled the interior tower's drainage. The size, type and direction of the lead out of the dedicated for this purpose pipe was left to the designer of the foundation, because this is not essential for the supplier of the turbine set.

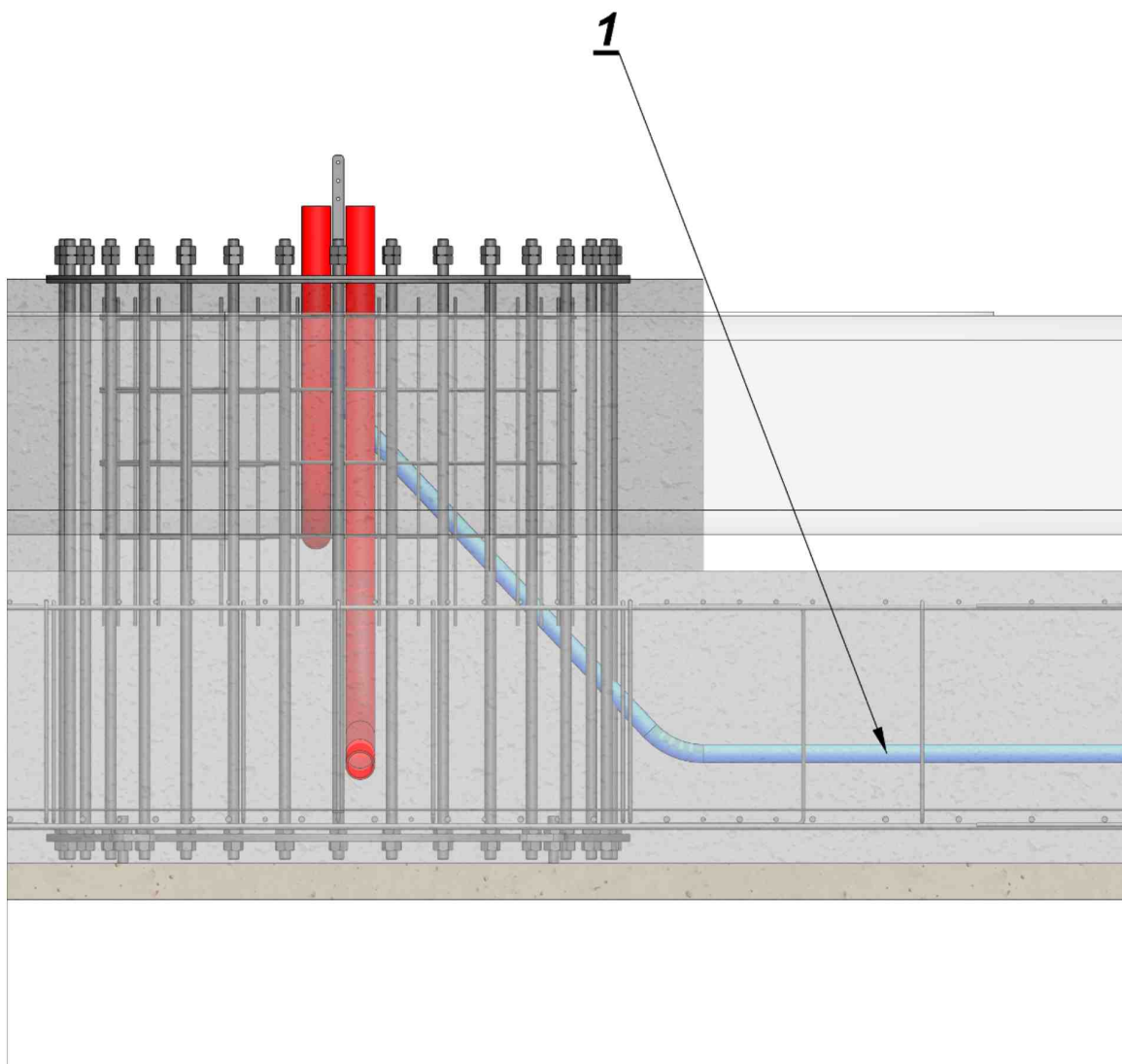

Fig.10. Grounding bar and protective pipes led out from the ZEFIR D14-P10-T23 turbine set foundation.

1- drainage pipe

5. Computational load cases of the wind turbine foundation

The foundation of the wind power plant is laden by balance of forces and torques from the weight of the wind turbine, the forces of inertia of the rotating rotor and the wind pressure on the working rotor, turbine nacelle and tower.

The system, which determines the size of these forces and torques, has start at point F, Fig. 11. This point is located in the axis of the foundation at the level of the anchor basket top flange, Fig. 16.

ZEFIR D14-P10-T23 turbine operates at a variable speed. The supporting structure and foundation should be able to withstand extreme ad hoc loads and cyclic loads, induced by mass and aerodynamic rotor imbalance. The rotational speed of the rotor is variable in the range of $\omega=0\div 7.85$ [1/s] corresponding to the rotation of the rotor from the scope of $n=0\div 75$ [RPM].

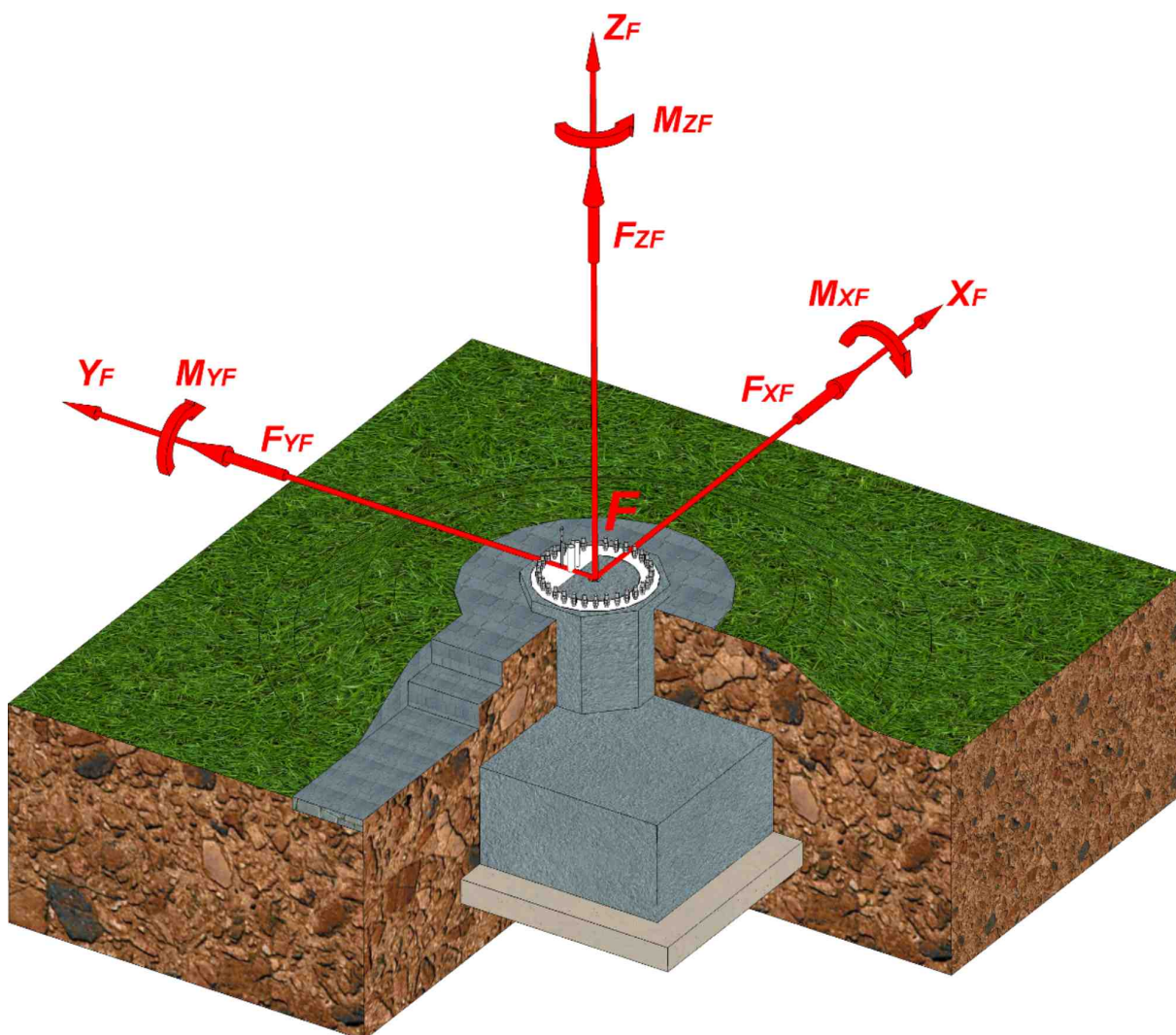

Fig. 11. The coordinate system to determine ZEFIR D14-P10-T23 wind turbine foundation loads.

5.1. Wind turbine operates at a nominal power

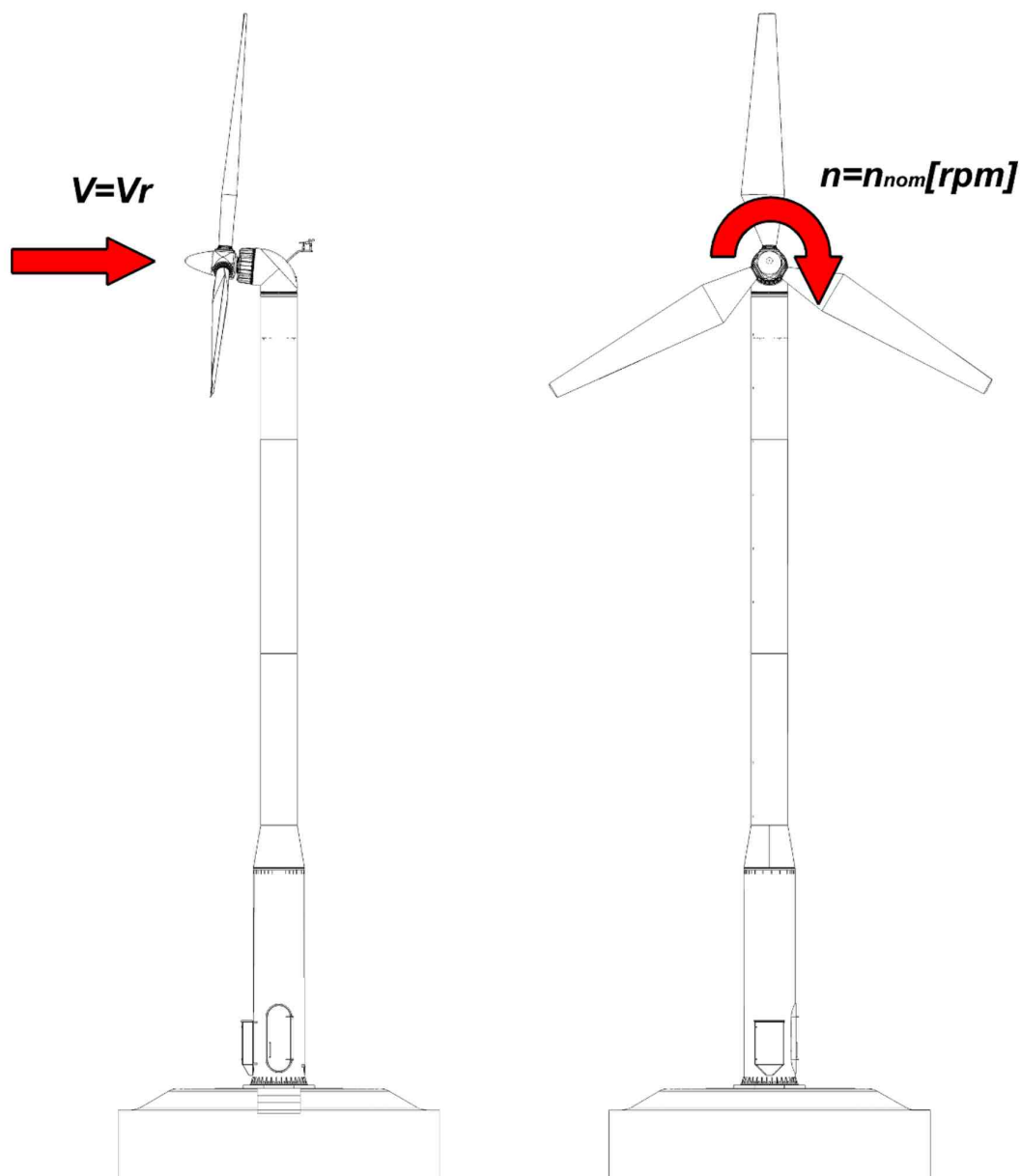

Fig.12. Wind turbine during operation with nominal power

Table 2. Loads acting on the foundation

Maximal forces	$F_{xf} = 3500[\text{N}]$ $F_{yf} = 0[\text{N}] + 1300[\text{N}]\sin(\omega t)$ $F_{zf} = -91000[\text{N}] + 1300[\text{N}]\cos(\omega t)$
Maximal torques	$M_{xf} = 1800[\text{Nm}] + 30700[\text{Nm}]\sin(\omega t)$ $M_{yf} = 60800[\text{Nm}] + 2000[\text{Nm}]\cos(\omega t)$ $M_{zf} = 3700[\text{Nm}] + 2000[\text{Nm}]\sin(\omega t)$

5.2. Turbine's failure at the turbine set's nominal power

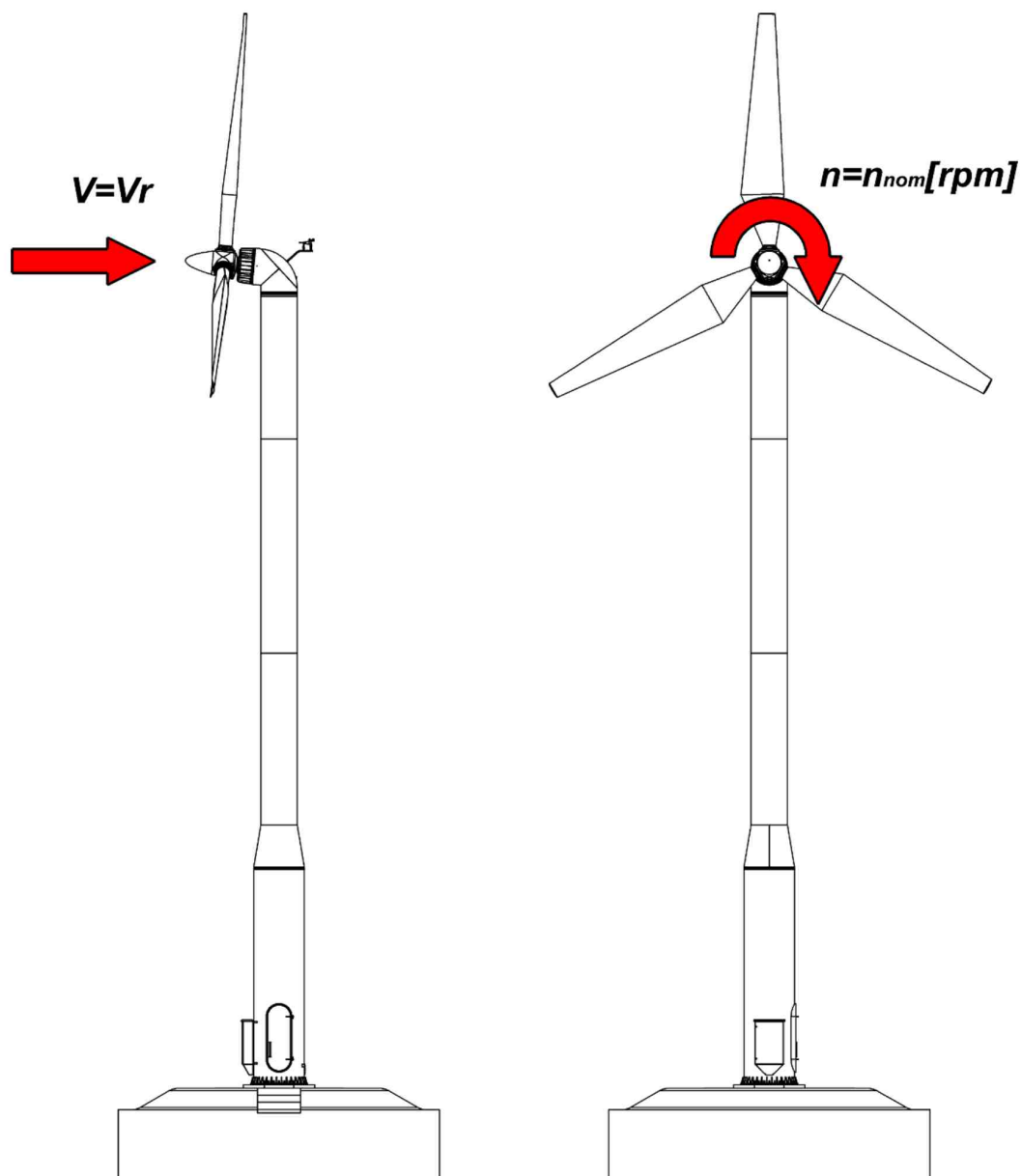

Fig.13. Emergency braking at nominal power.

Table 3. Loads acting on the foundation

Maximal forces	$F_{xf} = 9600[\text{N}]$ $F_{yf} = 10600[\text{N}]$ $F_{zf} = -91000[\text{N}]$
Maximal torques	$M_{xf} = 258000[\text{Nm}]$ $M_{yf} = 202500[\text{Nm}]$ $M_{zf} = 9300[\text{Nm}]$

5.3. Extreme wind blast in the rotor's axis at a stoppage

The wind power plant is not operating, the rotor blades of the turbine set with maximum exposure to the wind from the back, 50-year extreme wind blast $V_e=59,5[m/s]$ acc. EN61400-2:2014.

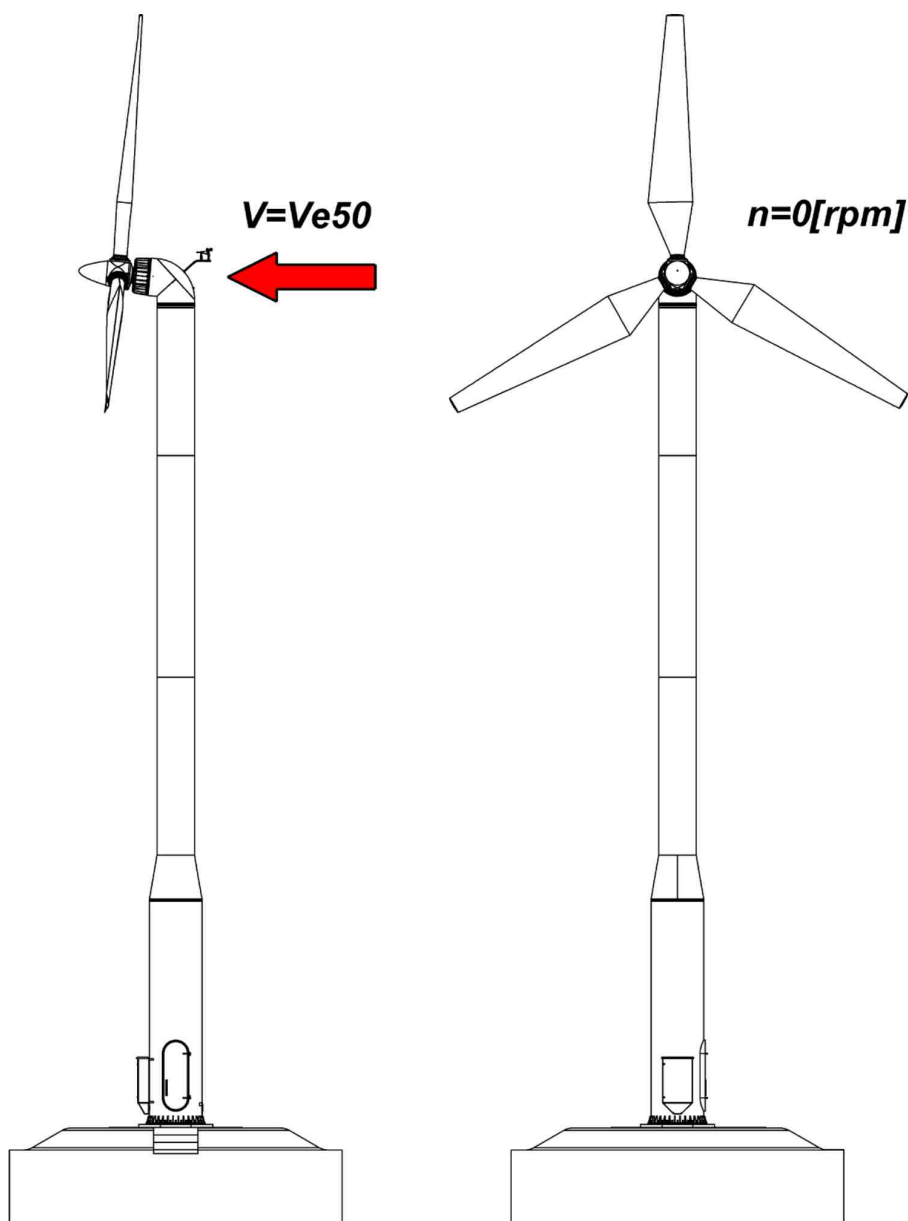

Fig. 14. Wind blast from the back of the rotor at a stoppage.

Table 4. Loads acting on the foundation

Maximal forces	$F_{xf} = -36300[N]$ $F_{yf} = 0[N]$ $F_{zf} = -91000[N]$
Maximal torques	$M_{xf} = 0[Nm]$ $M_{yf} = -1082200[Nm]$ $M_{zf} = 0[Nm]$

5.4. Extreme wind blast from the side at a stoppage

The wind power plant is not operating, the rotor blades of the turbine with maximum exposure to the wind from the side, 50-year extreme wind blast $V_e=59,5$ [m/s] acc. EN61400-2:2014.

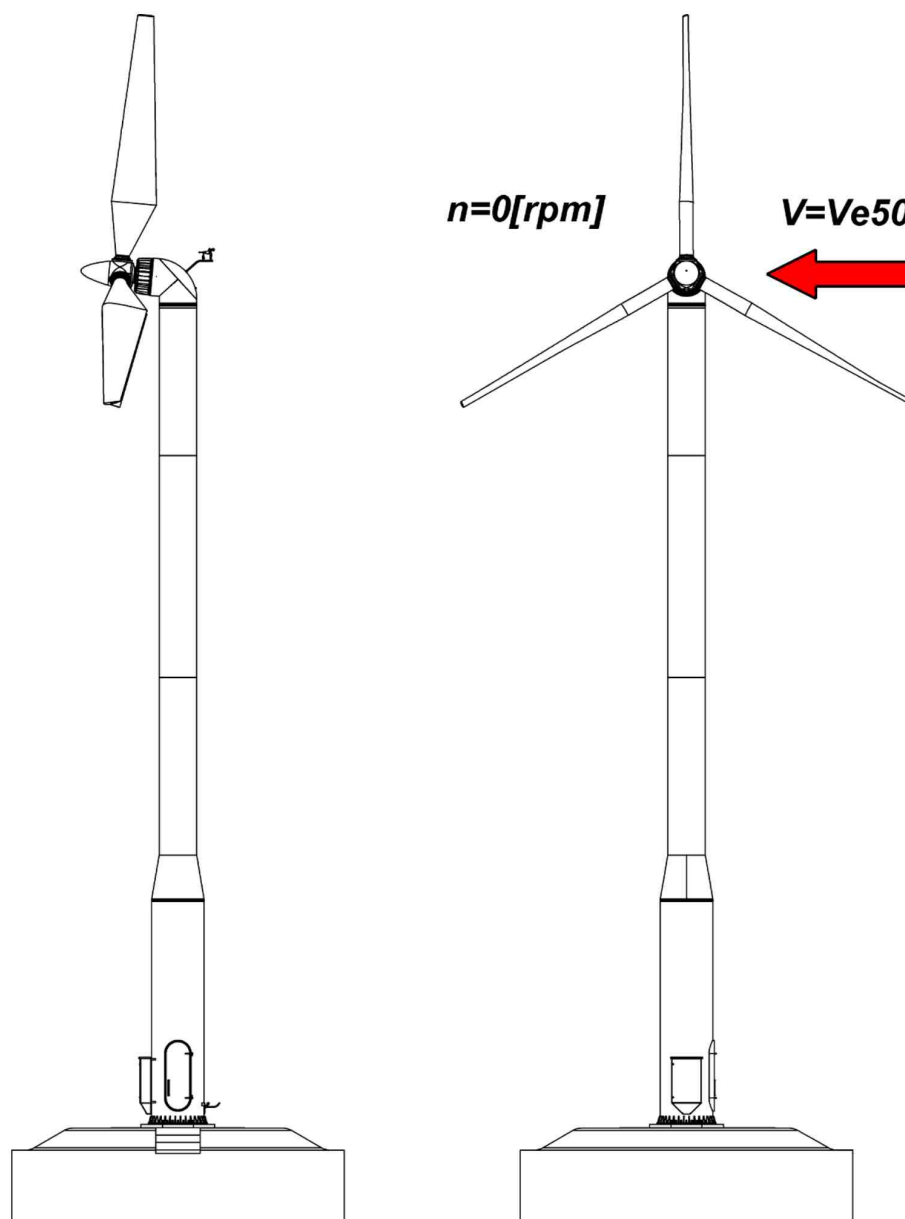

Fig. 15. The turbine rotor unfavorably positioned during maximum wind blast from the side.

Table 5. Loads acting on the foundation

Maximal forces	$F_{xf} = 0$ [N] $F_{yf} = 24200$ [N] $F_{zf} = -91000$ [N]
Maximal torques	$M_{xf} = 751900$ [Nm] $M_{yf} = -25700$ [Nm] $M_{zf} = 36300$ [Nm]

6. 6 Example of foundation.

The foundation is a structure for individual each location, and must be designed by a qualified building designer. This individuality is mainly due to the different capacity of the ground at the localisation of the turbine foundation and local legal conditions.

The example of the foundation shown below can not be treated as a project of the foundation. It was developed for the investor for the purpose of estimating the scale of the project for the typical, simple geological conditions. For calculations it was assumed a not layered and non-cohesive ground capacity $q_{nf}=150$ [kPa]. For these conditions and the concept of the square foundation (Fig.11.) was obtained the solution of usage of major materials as in Table 6.

More effective from the materials point of view, but technologically difficult is the foundation on a plan of circle. The choice of solution is left to the designer of the foundation.

During the implementation of the foundation particular attention should be paid to the anchor basket upper flange leveling. Anchor basket is equipped with adjustable feet. It is recommended to set the anchor basket on a lean concrete, immersing his feet in it. After the solidification of the concrete, before making the rebar, anchor basket should be leveled. After finishing the rebar and during the concreting of the foundation this ring's leveling should be under control.

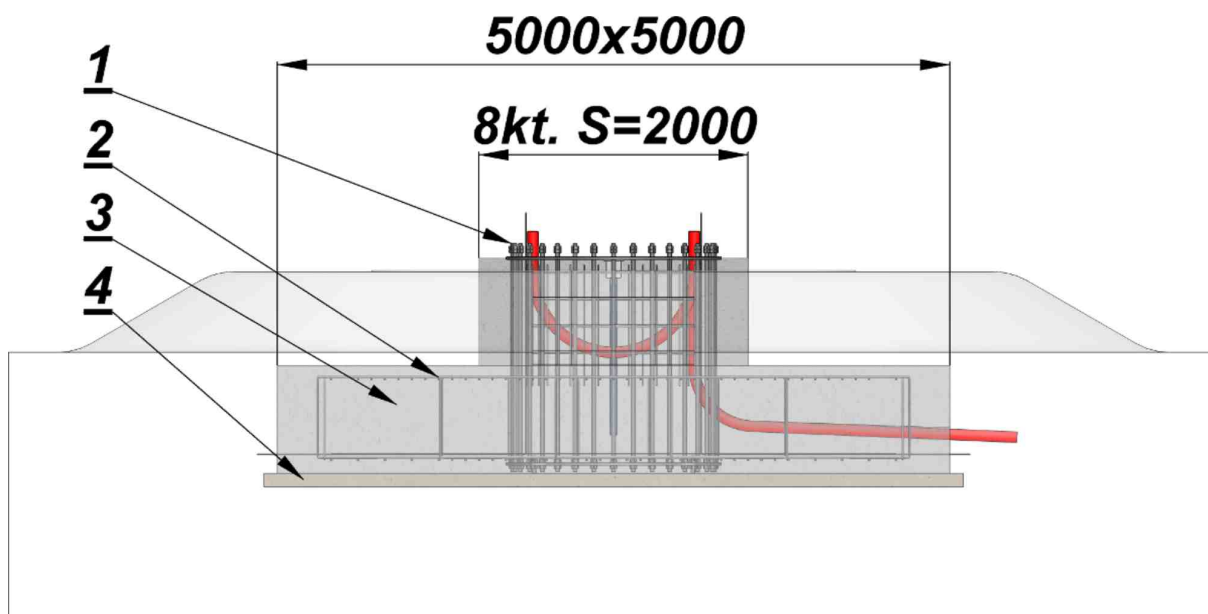

Fig.16. Overall dimensions of the exemplary foundation for the ZEFIR D14-P10-T23 turbine set.

1- Anchor basket, 2- Foundation block, 3- Rebar of the foundation block, 4- Lean concrete.

For the proposed foundation in the form of a square plate with a central plinth, the main element of a rebar is a system of two steel meshes, top and bottom, connected to corresponding stirrups, Fig. 17.

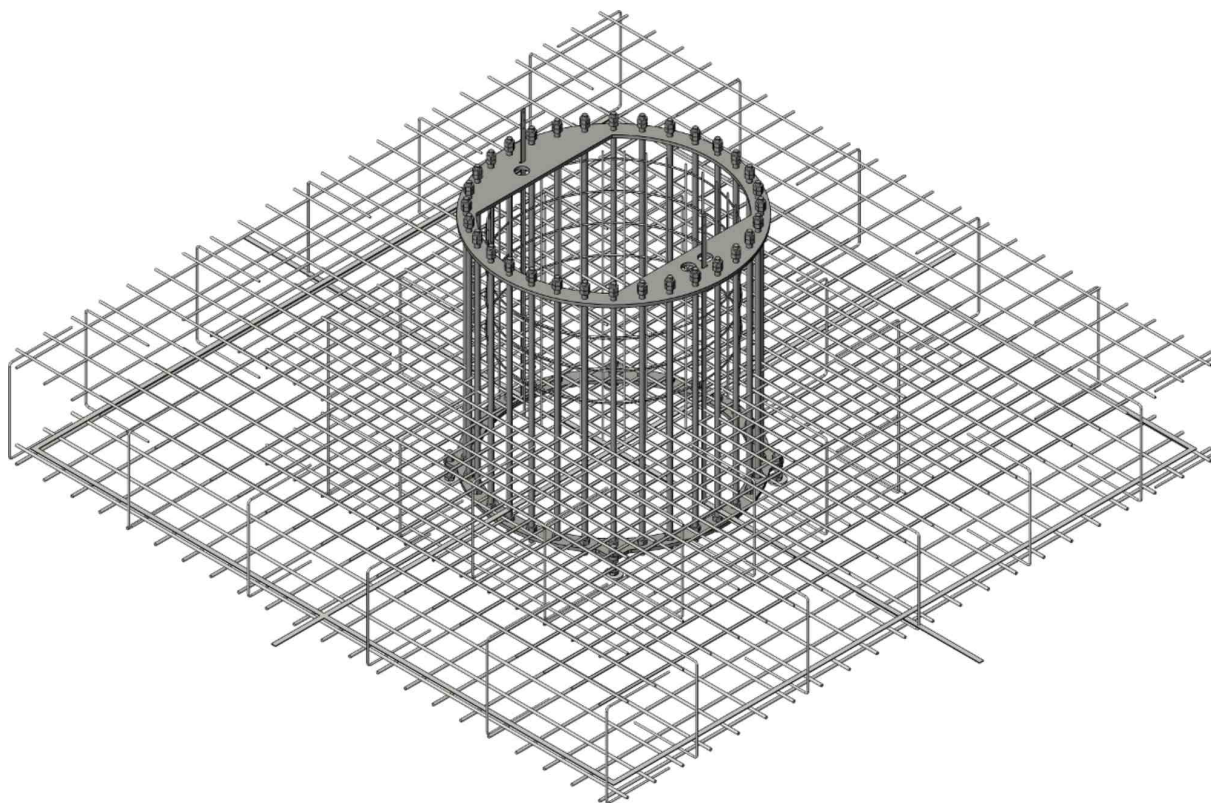

Fig. 17. The proposal of the exemplary foundation rebar structure.

The thickness of the bars and their number in the rebar, a foundation designer needs to determine in accordance with applicable laws, standards and construction practices.

Table 6. Usage of the main materials in the example foundation.

1	Lean concrete	approx. 6.2 m ³
2	Concrete for foundation block	approx. 21.0 m ³
3	Steel for rebar and the anchor basket	approx. 1560 kg
4	Spadework	approx. 72 m ³

7. Installation of the turbine set

The ZEFIR D14-P10-T23 wind turbine set parts are delivered to the installation site by trucks in special racks protecting the components from damage, and they are mounted on a foundation with an appropriate size crane.

When choosing the location for the power plant, should be provided appropriate access road for the typical size trucks and the crane. In addition, should be provided enough free area to set up a crane, maneuvering vehicles and power plants assembling components, and also temporary storage for parts to be assembled.

The tower of this power plant consists of 2 segments screwed together. In the first phase of the assembly the first segment of the tower is mounted on foundation. In the upper part of the first segment, there is a suitable platform, from which a flange junction is available for mounting of the second tower segment. The Figure 18 shows a final stage of the tower's assembling.

For installation of the ZEFIR D14-P10-T23 power plant tower or mast is required crane with lifting capacity of $G=4.0[T]$ with a hook at the height of $H=25[m]$. Elements should be lifted by grabbing tower's segments flanges, by fitting proper hitches in them.

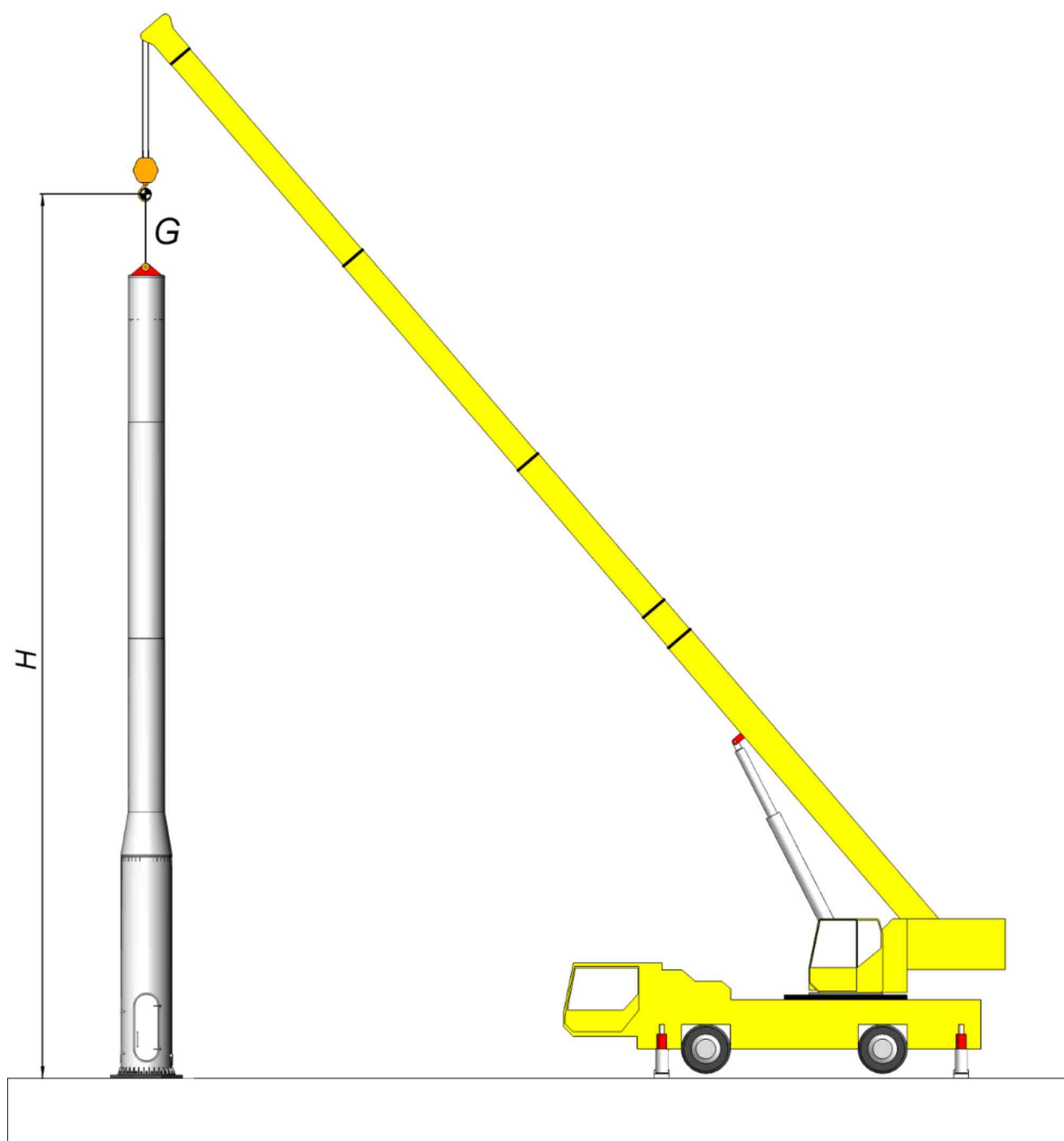

Fig. 18. The final moment of the assembling of the ZEFIR D14-P10-T23 power plant tower.

The next stage of the power plant assembling is a rotor blades assembling to the hub. Installation of blades is realized on the construction site after placing the head of power plant in a special stand, as in Fig. 19. A special sling is used for lifting the head, which allows to change the position of the head during the removal from the car and its placing on a stand.

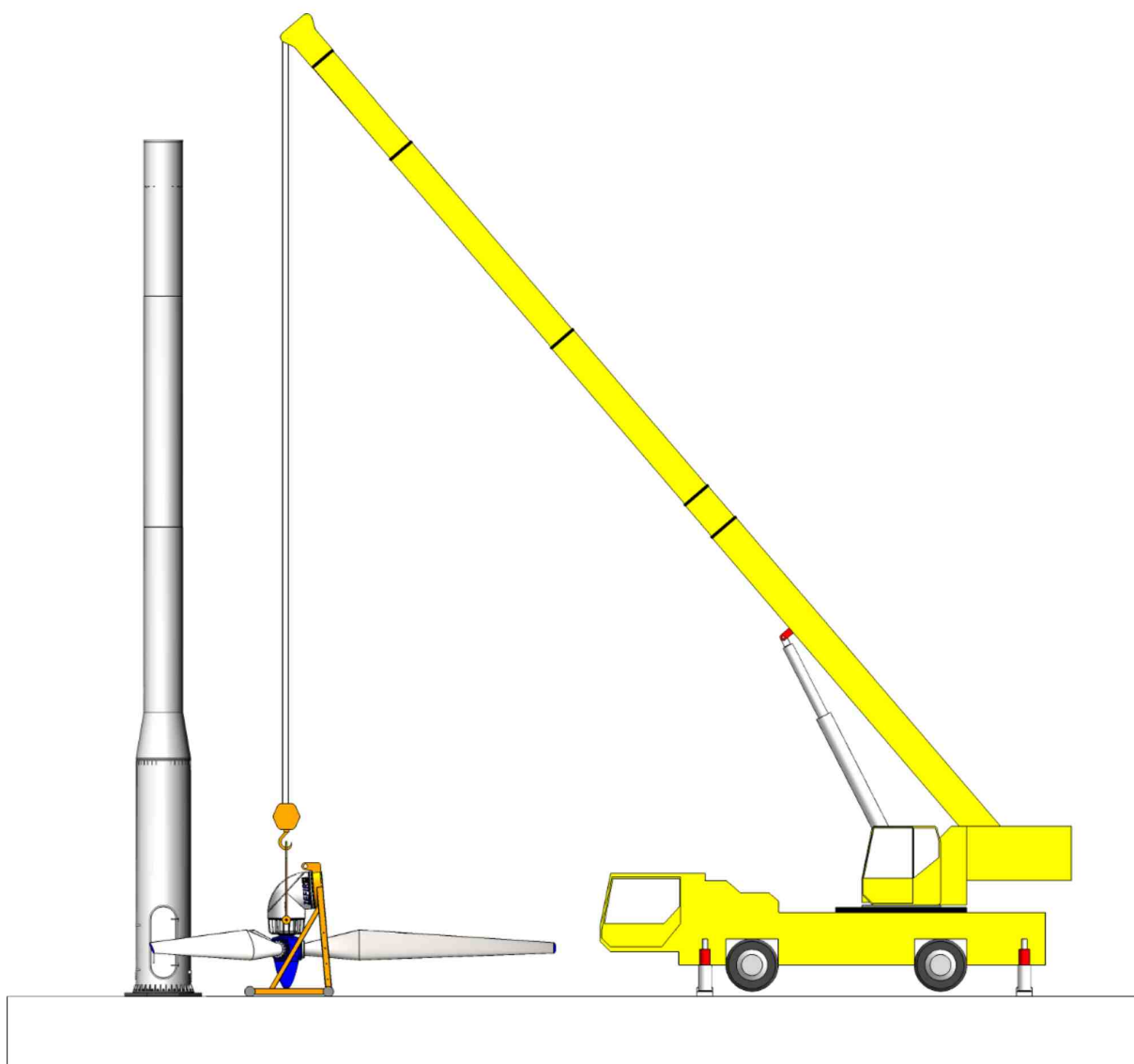

Fig.19. The ZEFIR power plant head during assembly of the rotor blades.

Due to the installation of all the rotor blades at the ground level, it is necessary to provide a sufficiently large free space for the power plant rotor. In the Fig.20. is an example of the position of the head relative to tower in case of limited space on the building site.

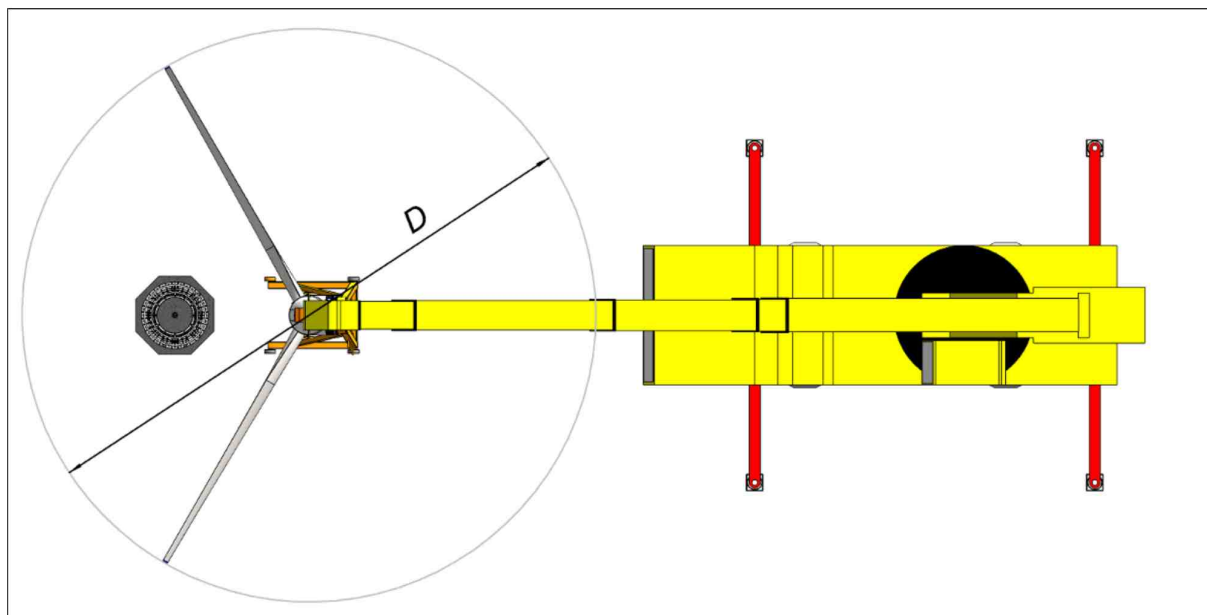

Fig.20. The ZEFIR power plant head during the rotor blades assembly. View from the top $D=14[m]$

The power plant head, including the rotor blades, is lifted using a special crane sling. Sling allows to rotate the head with a rotor to the position required for mounting on the top of tower, Fig.21.

Assembling the head to tower is realized by a team of installers from the fixed platform located near the top of tower's.

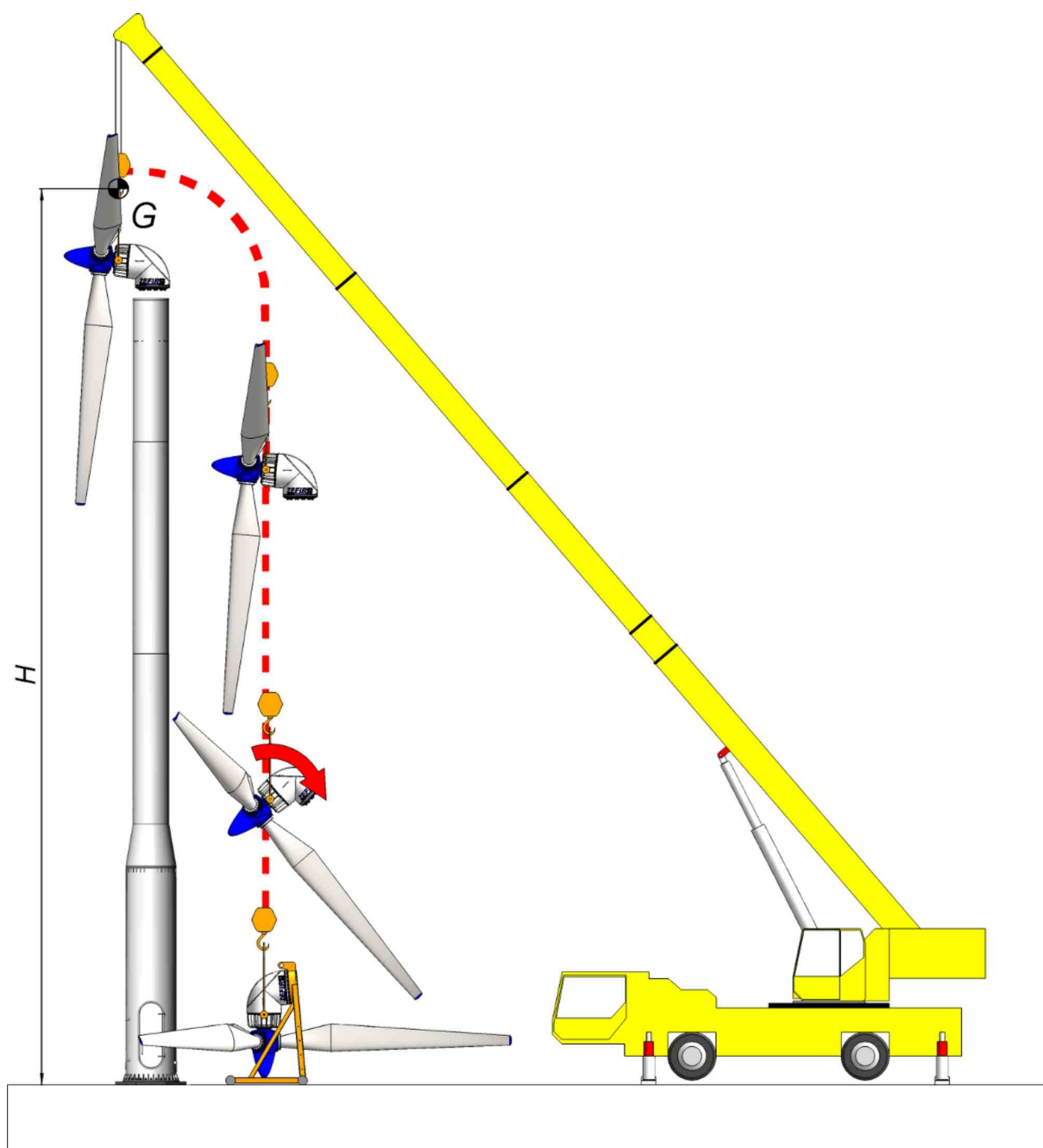

Fig.21. The operation of lifting and reorientation of the head of ZEFIR D14-P10-T23 power plant
 $H=25[m]$, $G= 2.8[T]$

8. Energetic installation

ZEFIR D14-P10-T23 wind turbine is a universal machine that can work:

- a) On-grid system, or
- b) Off-grid system - heating or/and battery charging.

Below presents typical diagrams of connecting the wind power plant to the customer's installation.

8.1. On-grid installation with the inverter located on the tower of the turbine set

In a situation where inverter can not be located in a building, it is installed on the tower of the power plant. In this case, the cable link (pos. 3, Fig. 22) is only a power cable. This cable is led out from the inverter through the foundation as discussed in section 4.2.

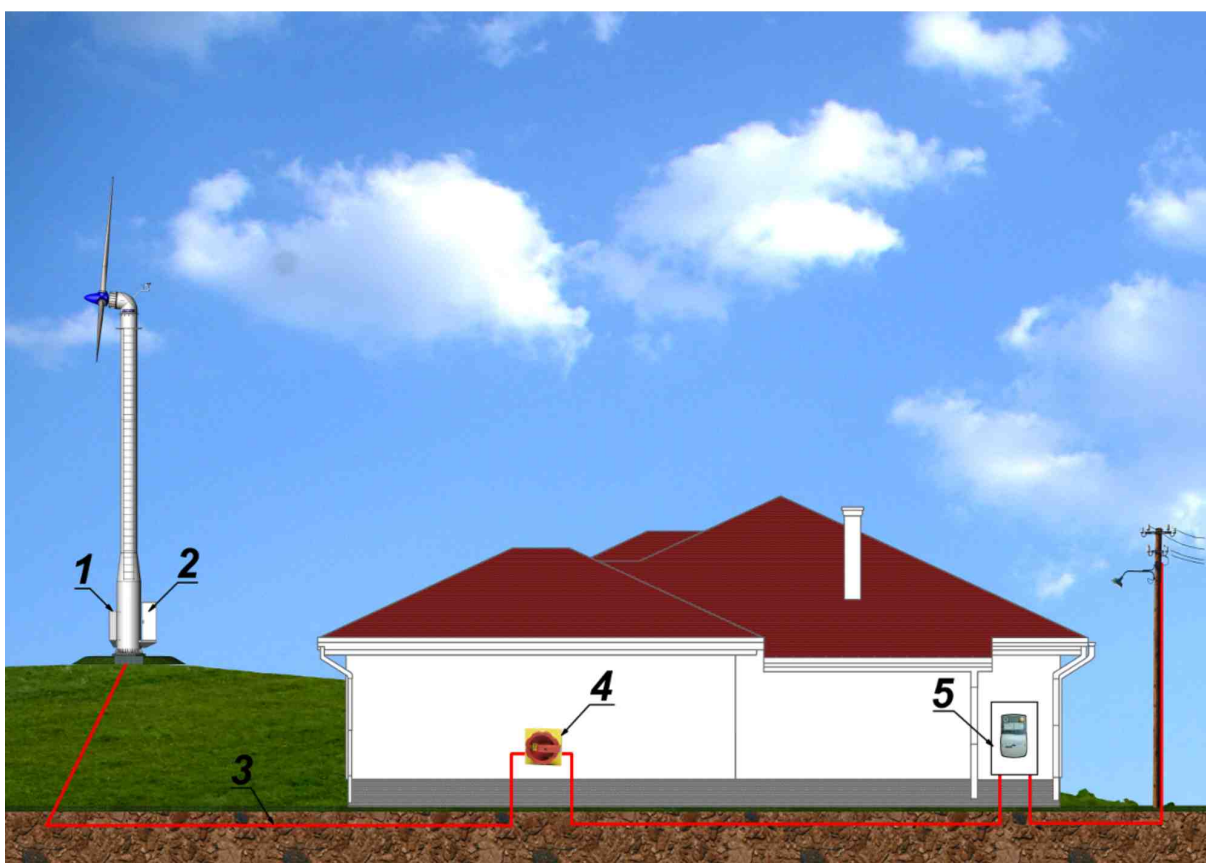

Fig.22. Wiring diagram of the ZEFIR D14-P10-T23 power plant working in on-grid system with inverter located on the tower of the power plant. 1-power plant control cabinet, 2- the inverter, 3- cable link from the power plant to the building, 4- switch, 5- electric meter

Parameters of land Power cable pos.3 should be selected depending on the distance from the power plant to the place of consumption. Our proposal of parameters of the power cable is given in Table 7.

Type and method of cable routing must be determined by a licensed energetics designer in accordance with applicable regulations and standards.

In the building, in an accessible place must be installed a power plant switch, in the form of a three-phase circuit breaker, appropriate for the power of 10kW.

Table 7. Selection of the power cable parameters

No.	The distance from the turbine set to the building	Min. cable cross-section
1	<50m	5 x 4mm ²
2	<100m	5 x 6mm ²
3	<500m	5 x 16mm ²

Inverter and power plant control cabinet are equipped with appropriate overvoltage, overcurrent and ground fault protection and do not require installation of additional protections.

Cable link between the electric meter and the inverter (turbine set) should have overcurrent protection in accordance with applicable regulations in this regard.

8.2 On-grid installation with inverter in the building

If in the project is expected to install the inverter in a building near the connection of the power plant to the network, fig. 23, then cable link pos.3 consists of three wires:

- a) Power cable,
- b) Turbine standby consumption cable, and
- c) Signal cable.

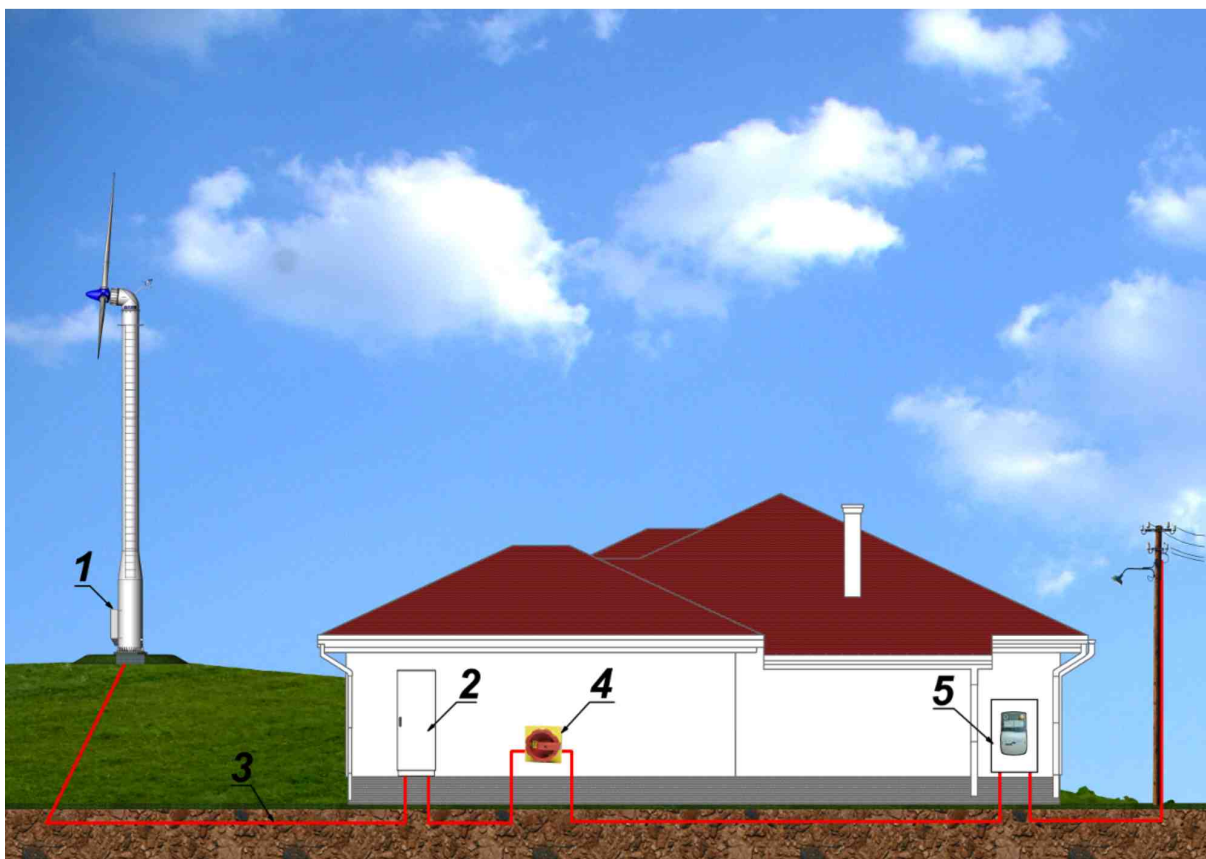

Fig.23. Wiring diagram of the ZEFIR D14-P10-T23 power plant working in on-grid system with inverter located in the building. 1- power plant control cabinet, 2- the inverter, 3- cable link from the power plant to the building, 4- switch, 5- electric meter

In this case, a power cable connection pos.3 provides electrical power with variable voltage and frequency directly from the generator to the inverter in the building.

By turbine standby consumption cable, three-phase voltage is applied from the grid in the building to the power plant control cabinet, item 1. fig. above. This voltage is taken from the inverter output voltage terminal.

For the communication between control system and the inverter it is necessary to install the paired, double-shielded signal cable.

As a consequence, the power link pos.3. consists of the three cables with the parameters which we proposed (Table 8).

Table 8. Selection of power and signal cables parameters

No.	The distance from the turbine set to the building	Min. cable cross-section
1	<50m	4 x 4mm ² + 5 x 2,5mm ² + 2 x (2 x 0.75)mm ²
2	<100m	4 x 6mm ² + 5 x 2,5mm ² + 2 x (2 x 0.75)mm ²
3	<500m	4 x 16mm ² + 5 x 4mm ² + 2 x (2 x 0.75)mm ²

In this case, the place for installation of the inverter should be predicted. ZEFIR D14-P10-T23 turbine is normally equipped (as standard) with an ELPOWER CLEANVERTER 10TL inverter.

Installation conditions of this inverter inside the building presents fig.24. Other data of the inverter can be found at www.elpower.it.

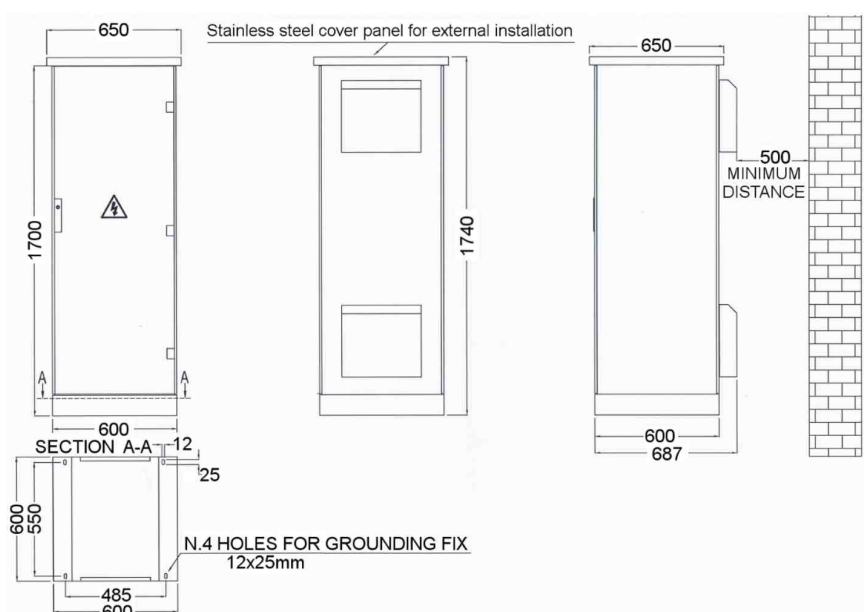

Fig.24. Installation conditions of the CLEANVERTER 10TL inverter in the building.

Inverter and power plant control cabinet are equipped with appropriate overvoltage, overcurrent and ground fault protection, and both them and the power cable (pos.3 in Fig. 23) do not require installation of additional protections.

Cable link between the electric meter and the inverter (turbine set) should have overcurrent protection in accordance with applicable regulations in this regard.

The main switch, pos.4, cuts power to both standby consumption needs (which disables the power plant) and the energy supply from the wind turbine to the grid. This switch should be appropriate to the power of 10kW and installed in an accessible place.

8.3 Off-grid installation

In the situation the wind turbine is working on a separate network (off-grid), fig. 25, it is necessary to use a special D14-P10 Load Controller instead of the inverter. This controller allows the controlled battery charging and the transfer of excess energy to the heating system. Part of the energy from the battery is used for the supply the wind turbine standby consumption needs, the rest for the building power supply. Such user installation must be individually designed in contact with our technical office to take account of the specificity of powered facility. This applies mainly to for the power distribution ratio for the accumulation and the heating. In extreme cases, you can consider the transmitting of the whole energy to the heating system or for the accumulation. In the first case, remember to provide power for the turbine standby consumption needs. In the second case, remember about the inevitable losses in energy production during periods of surplus power generation, related to the battery maximum charging power. These requirements must be included in the software and the Load Controller output power stages.

The following Fig. 25 shows a typical diagram such installation.

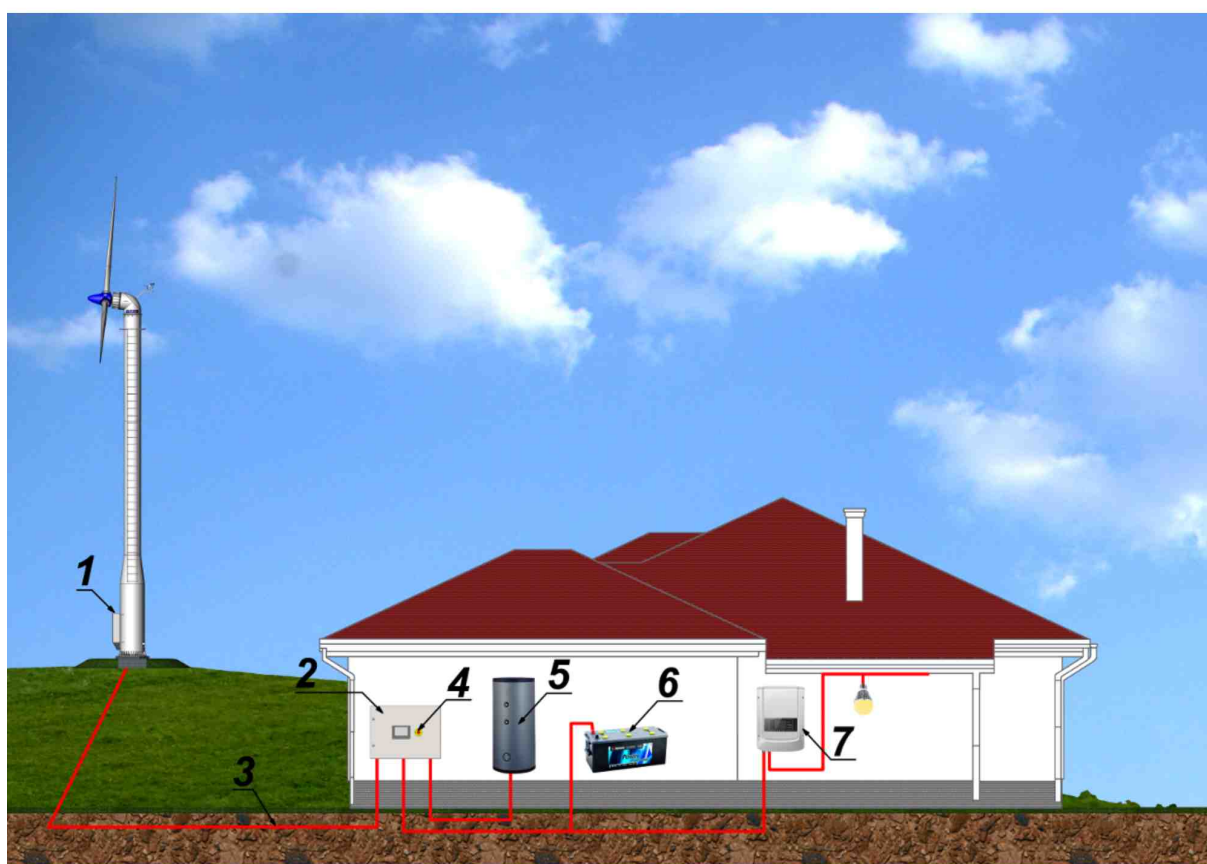

Fig.25. ZEFIR D14-P10-T23 power plant off-grid wiring diagram with the load generator in the building.

1- power plant control cabinet, 2- load controller, 3- cable link from the power plant to the building, 4- switch, 5- D.H.W. (Domestic hot water) tank, 6- rechargeable battery, 7- inverter.

Load controller and power plant control cabinet are equipped with appropriate overvoltage, overcurrent and ground fault protection, and both them and the power cable (pos.3) do not require installation of additional protections.

Cable link (pos.3) consists of three wires:

- a) Power cable, provides electrical power with variable voltage and frequency from the turbine set to the Load Controller,
- b) Turbine standby consumption cable, and
- c) Signal cable, for communication between the Control cabinet and the Load Controller.

Both the external and internal electrical installation of the building must be designed by a qualified electrical designer, in accordance with the applicable standards and regulations.

Below we propose the parameters of cables of link number 3 in Fig. 25.

Table 9. Selection of power and signal cables parameters

No.	The distance from the turbine set to the building	Min. cable cross-section
1	<50m	4 x 4mm ² + 5 x 2,5mm ² + 2 x (2 x 0.75)mm ²
2	<100m	4 x 6mm ² + 5 x 2,5mm ² + 2 x (2 x 0.75)mm ²
3	<500m	4 x 16mm ² + 5 x 4mm ² + 2 x (2 x 0.75)mm ²

The main power switch is an integral part of the Load Controller. Dimensions and Load Controller installation conditions are determined individually on the basis of the requirements, relating to the energy separation for heating and accumulation.

8.4. Schematic diagrams of the system main components

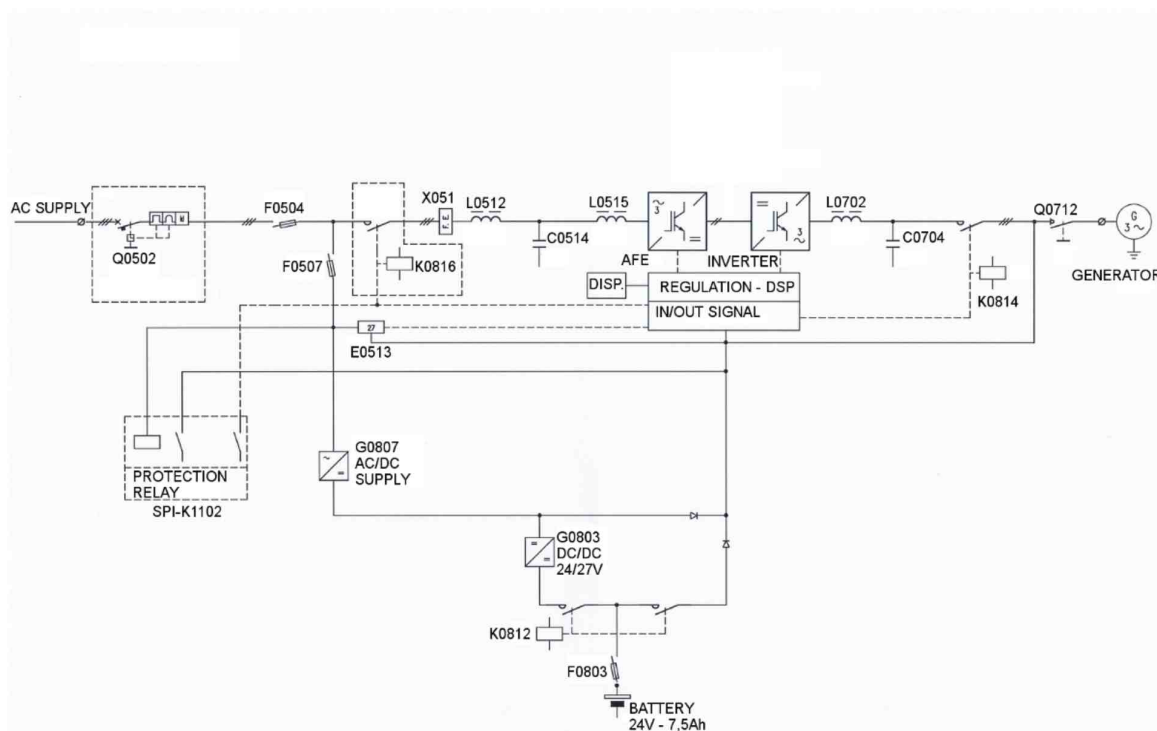

Fig.26. Schematic diagram of the CLEANVERTER 10TL, ELPOWER

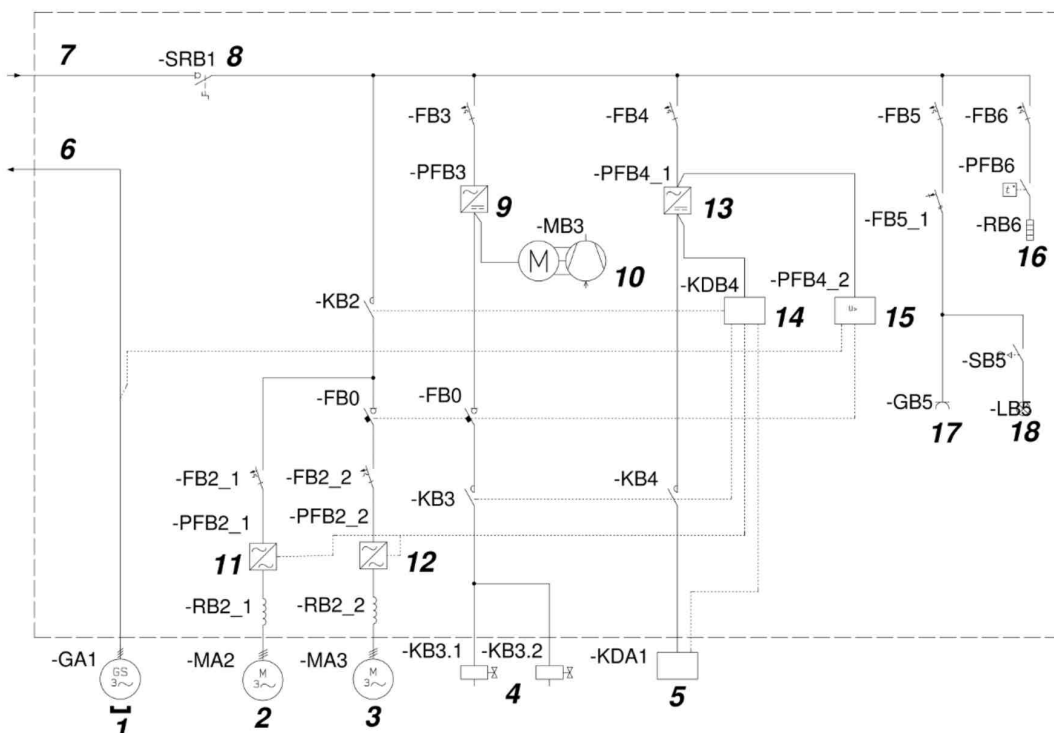

Fig.27. Schematic diagram of the D14-P10 control cabinet (pos. 1. at the Fig. 18, 19 and 20) ZEFIR D14-P10-T23 power plant

1- generator, 2- yaw mechanism drive, 3- pitch control drive, 4- pneumatic brakes, 5- data concentrator, 6- energy produced by power plant, 7- standby consumption needs, 8- standby consumption needs switch, 9- 24VDC transformer, 10- compressor, 11- inverter, 12- inverter, 13- 24VDC power supply, 14- PLC controller, 15- Overvoltage relay, 16- cabinet heating, 17- service socket, 18- cabinet lighting.

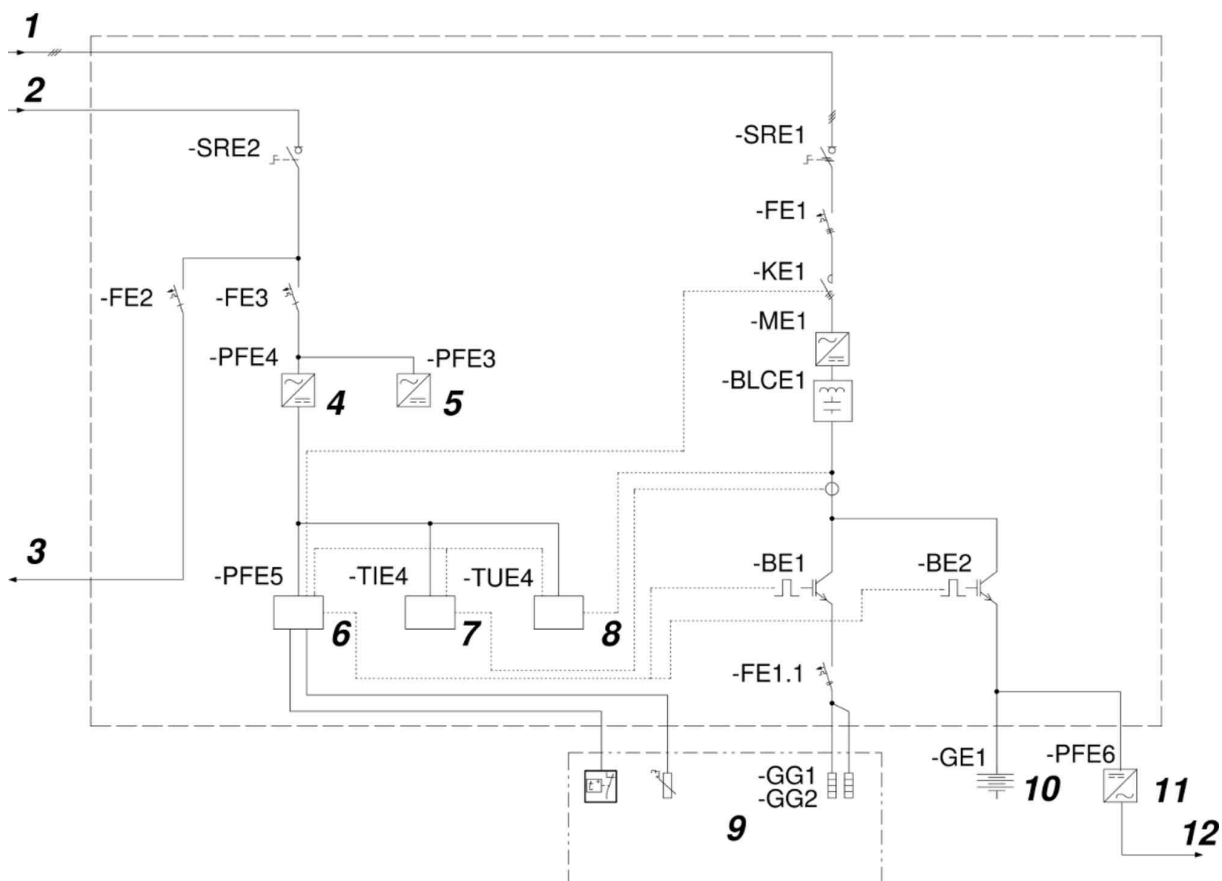

Fig.28. Schematic diagram of the D14-P10 Load Controller (pos. 6 on the fig.20) of the ZEFIR D14-P10-T23 power plant

1- energy produced by power plant, 2- load controller power supply, 3- standby consumption needs, 4- 24VDC power supply, 5- 15VDC power supply, 6- PLC controller, 7- current transducer, 8- voltage transducer, 9- D.H.W. (Domestic hot water) tank, 10- rechargeable battery, 11- inverter, 12- receivers power supply.

9. Grounding and lightning protection

For proper wind turbine operation, it is necessary to install the grounding and lightning protection systems.

Fig. 29 presents a suggestion of grounding. It is a grounding made with the foundation of the 30 mm x 4 mm flat steel bar, protected against corrosion by copper coating. This flat bar is embedded in a foundation block on its edges and welded to the rebar inside the foundation block.

We suggest to lead the grounding wires endings outside the foundation block, into the control and measurement wells. In the case of not achieving the required conductivity of the grounding, it gives the possibility of its expansion with additional earth electrodes, for example vertically guided.

It is required to achieve the electric resistance below 10Ω.

Flat grounding bar should be led out from the base of the foundation through the prepared hole in the anchor basket top flange, as shown in Fig. 5, 6, and 7. Mounting holes, shown at the end of the flat bar, should be made, and during the concreting, the flat bar should be locked in the desired position in relation to the anchor basket flange.

The grounding project, which takes into account local ground conditions and law regulations, must be designed by a qualified electrical designer.

The power plant lightning arrester is led as a turbine set elements galvanic connection from the rotor blades to the steel tower, and it is connected with the grounding discussed above.

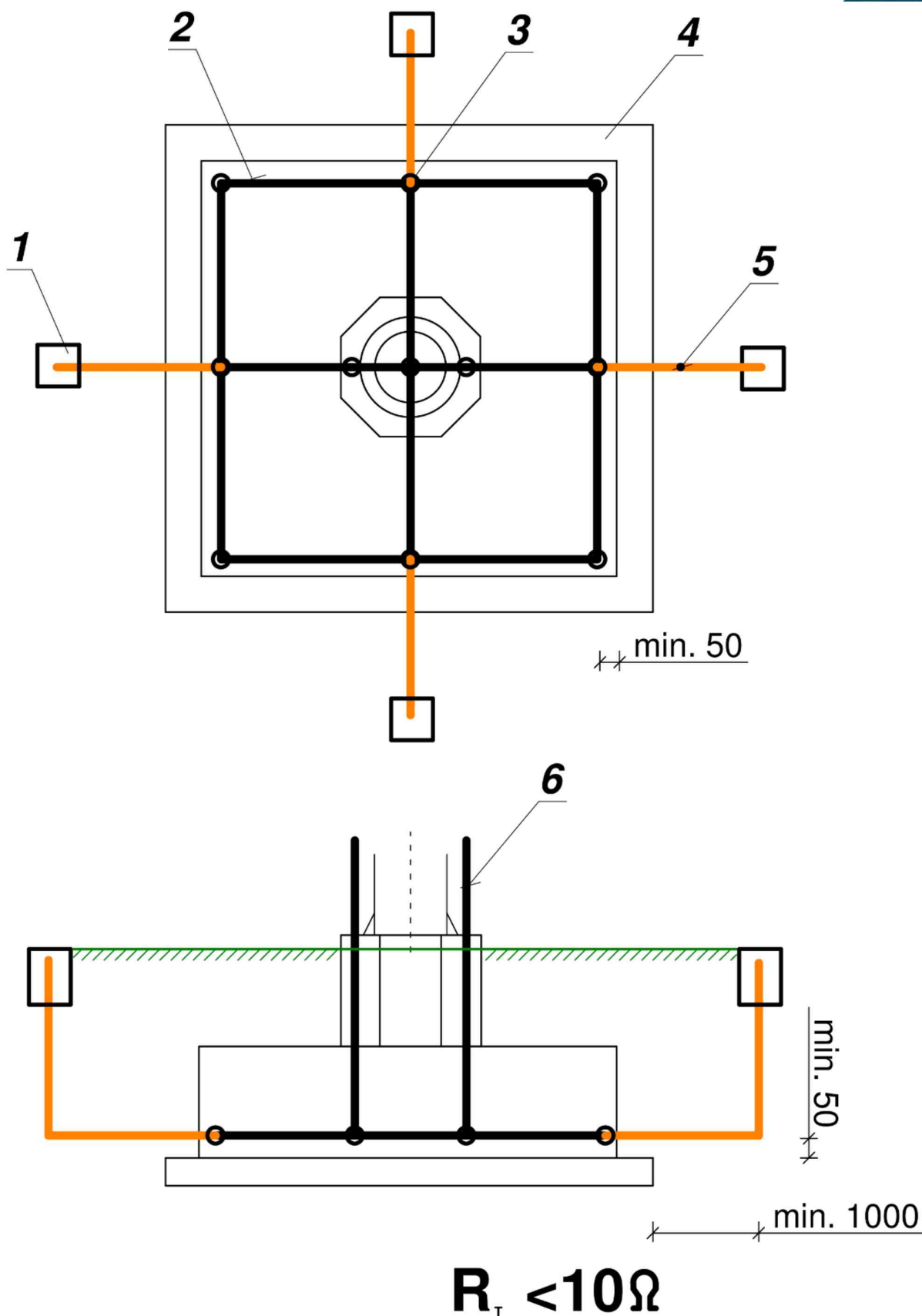

Fig.29. Proposition of grounding system of the ZEFIR D14-P10-T23 wind turbine, 1- control and measurement well, 2- steel grounding tape 30x4, 3- flat oblique holder, 4- foundation, 5- steel grounding tape 30x4, copperweld with Cu min. 0,070mm, 6- steel grounding tape copperweld with Cu min. 0,070, with tinning.